



NCEA
NATIONAL CENTRE FOR ENGINEERING IN AGRICULTURE

A Protocol for assessing on-farm energy use and greenhouse gas emissions.

NEC1101 – Final Report

Sandell G.R., Baillie C.P., Chen G., Szabo P.M., Woodhouse N.P., Khabbaz B.G.

National Centre for Engineering in Agriculture

University of Southern Queensland

Toowoomba

NCEA Publication 1004068/1

September 2013



UNIVERSITY
OF SOUTHERN
QUEENSLAND



NCEA

National Centre for
Engineering in Agriculture



NCEA
National Centre for
Engineering in Agriculture

Disclaimer

While the National Centre for Engineering in Agriculture and the authors have prepared this document in good faith, consulting widely, exercising all due care and attention, no representation or warranty, express or implied, is made as to the accuracy, completeness or fitness of the document in respect of any user's circumstances. Suppliers, companies and their products mentioned in this document do not infer endorsement by the NCEA. Users of the report should undertake their own quality controls, standards, safety procedures and seek appropriate expert advice where necessary in relation to their particular situation or equipment. Any representation, statement, opinion or advice, expressed or implied in this publication is made in good faith and on the basis that the National Centre for Engineering in Agriculture, its agents and employees, and the Cotton Research and Development Corporation (the commissioning Agency) are not liable (whether by reason of negligence, lack of care or otherwise) to any person for any damage or loss whatsoever which has occurred or may occur in relation to that person taking or not taking (as the case may be) action in respect of any representation, statement or advice referred to above.

Published in September 2013 by the National Centre for Engineering in Agriculture, Toowoomba. Material from this publication may not be used unless prior written approval has been obtained from the National Centre for Engineering in Agriculture and the Cotton Research and Development Corporation.

This document should be cited as follows:

Sandell G.R., Baillie C.P., Chen G., Szabo P.M., Woodhouse N.P., Khabbaz B.G. (2013). A Protocol for assessing on-farm energy use and greenhouse gas emissions. Cotton Research and Development Corporation report. National Centre for Engineering in Agriculture, Publication 1004068/1, USQ, Toowoomba.



FINAL REPORT 2013

Part 1 - Summary Details

Please use your TAB key to complete Parts 1 & 2.

CRDC Project Number: **NEC1101**

Project Title: A Protocol for Assessing On Farm Energy Use
and Associated Greenhouse Gas Emissions

Project Commencement Date: 1/07/2010 **Project Completion Date:** 30/06/2013

CRDC Program: **Farming Systems**

Part 2 – Contact Details

Administrator: Craig Baillie, Director
Organisation: National Centre for Engineering in Agriculture (NCEA)
Postal Address: NCEA, C/- USQ, West Street, Toowoomba, 4350
Ph: 07 4631 2071 **Fax:** 07 4631 1870 **E-mail:** Craig.Baillie@usq.edu.au

Principal Researcher: Gary Sandell
Organisation: NCEA
Postal Address: As above
Ph: 07 4631 5396 **Fax:** 07 4631 1870 **E-mail:** gary.sandell@usq.edu.au

Supervisor: Craig Baillie
Organisation: NCEA
Postal Address: As above
Ph: 07 4631 2071 **Fax:** 07 4631 1870 **E-mail:** Craig.Baillie@usq.edu.au

Researcher 2 Dr Guangnan Chen
Organisation: NCEA
Postal Address: As above
Ph: 07 4631 2518 **Fax:** 07 4631 1870 **E-mail:** Guangnan.Chen@usq.edu.au

Signature of Research Provider Representative:

Executive Summary

Declining oil reserves and increasing oil demand are maintaining strong upward pressure on the price of energy. Peak oil and an exponentially expanding world population ensure that energy prices are going to rise an increasing pace. Rising energy costs are particularly acute for agriculture, which relies on energy intensive process to manufacture the fertilisers and chemicals necessary to achieve the yields required for economic viability. Energy policy debates continue and add uncertainty to the energy supply equation. Producers are certainly aware of rising energy costs.

Increased greenhouse emissions and global warming places further limits on water, land, energy and other resources and meeting the demands of an expanding world population is becoming increasingly difficult. There is scientific certainty that climate change is real; the exact impacts of this are not fully understood.

Because cotton is a highly mechanised and high-input crop which relies heavily on diesel, fertilisers, chemicals, water and land, meeting the energy challenge is particularly important to Australian cotton production.

To address these concerns, a CRDC-funded project entitled '*A protocol for assessing on farm energy use and associated greenhouse gas emissions*' investigated how the cotton industry can identify and reduce their energy use. The project has a range of outcomes, including:

- A protocol for measuring energy use in cotton production, which is contained in the document "A standardised practical methodology for benchmarking on-farm energy use and greenhouse gas emissions on cotton farms."
- a library of energy use benchmarks for various operations
- an upgraded version of EnergyCalc, an on-line software tool that now encapsulates these, with other lessons from the project.

Together, these outputs enable a novice person with estimation techniques that are acceptable method of performing an energy analysis that is relevant to their individual situation. The protocol for measuring energy use is a how-to guide that steps the user through an energy audit. And this guide works in conjunction with the EnergyCalc software. The EnergyCalc software incorporates the library of energy use benchmarks for various operations and this gives the user the ability to estimate energy use even when no measured energy information is available.

The project found that there is less variation in in-field operations and pumping has a potential for up to 30% energy savings – pumping consumes 50 to 70% of all energy directly consumed on-farm. The project also identified that fertiliser and chemical account for much larger amounts of energy, which are used in-directly on-farm. Other potential areas for energy, cost and GHG gas savings include tillage efficiency, water application efficiency.

Once adopted, these will result in a cotton industry that is more viable economically and better placed to meet the increasing demands of rising energy costs. Any reductions in energy use will also reduce the carbon footprint of the industry, which, as most cotton is exported, adds to the 'clean and green' image of Australian cotton production.

For more details of this research please contact Craig Baillie at the NCEA Ph: +61-7-4631-2071 or email craig.baillie@usq.edu.au

Table of Contents

Executive Summary.....	iii
Table of Contents.....	iv
1. Background.....	1
2. Objectives.....	2
3. Protocols for Energy Measurement.....	2
3.1. Energy Assessment Methodology.....	3
3.1.1. On and Off-farm, Direct and Indirect Energy Use.....	4
3.1.2. Conversion Factors.....	5
3.1.3. Audit Types.....	6
3.1.4. Measurement Accuracy.....	8
3.1.5. Assessment Reporting.....	8
3.2. EnergyCalc.....	8
3.2.1. EnergyCalc Lite.....	10
4. Case Study Methodology – Level One and Level Two Assessments.....	11
4.1. Detailed Monitoring Methodology – Level Three Assessments.....	12
4.1.1. Tractor Monitoring.....	12
4.1.2. Pump Monitoring.....	13
5. Energy Benchmarking Results.....	15
5.1. Benchmarking Energy Use Using Standard Assessments – Level One Results.....	15
5.2. Quantifying Individual Operations – Level Two Results.....	16
5.2.1. Irrigation Energy.....	16
5.2.2. In-field Operations.....	16
5.3. Level Three Assessments Results.....	19
5.3.1. Tractor Monitoring.....	19
5.3.2. Pump Monitoring.....	22
5.4. Energy Assessments, Accuracy and Reporting.....	26
6. Energy Use and GHG Emissions for Alternative Production Systems.....	27
6.1. Life Cycle Energy Use.....	27
6.2. Characterising On-farm Energy Use and GHG Emissions for Different Production Systems and Locations.....	28
7. Project Outcomes.....	29
7.1. Opportunities to Reduce Energy Use and GHG emissions.....	31
7.1.1. Energy Demand.....	32

7.1.2.	Energy Source	34
7.1.3.	Tariffs and costs	36
8.	Conclusions	37
9.	Extension Opportunities	38
	References	40
	Appendix A: A standardised practical methodology for benchmarking on-farm energy use and greenhouse gas emissions on cotton farms.	42
	Appendix B: EnergyCalc Users' Manual	68
	Appendix C: EnergyCalc Information Sheet	80
	Appendix D: EnergyCalc Input Sheet.....	85
	Appendix E: EnergyCalc Report.....	97
	Appendix F: Tractor monitoring and the ISOBUS standard	125
	Appendix G: Promoting Energy Assessment and Reporting Tools	129

1. Background

Peak oil demands and declining oil reserves, increased greenhouse emissions and global warming and economic drivers for operational and cost efficiencies promote energy efficiency as one of the most important global issues. Meeting the demands of an expanding world population is becoming increasingly difficult not only as the global climate changes but as further limits are placed on water, land, energy and other resources. Rising energy costs are particularly acute for agriculture, which relies on energy intensive process to produce necessary fertilisers and chemicals. Because cotton is a highly mechanised and high-input crop which relies on diesel, fertilisers, chemicals, water and land, meeting the energy challenge is particularly important to Australian cotton production.

Energy efficiency is an important consideration for agriculture both in terms of rising energy costs. Australia's electricity prices have increased by 80% in the last 5 years, which has far exceeded the increases in consumer price index changes in the same period. It is projected that electricity prices in Australia will further increase by another 30% in the next 2 years. Hence, there is increased importance in quantifying energy use, as a step toward encouraging efficient energy use on the farm.

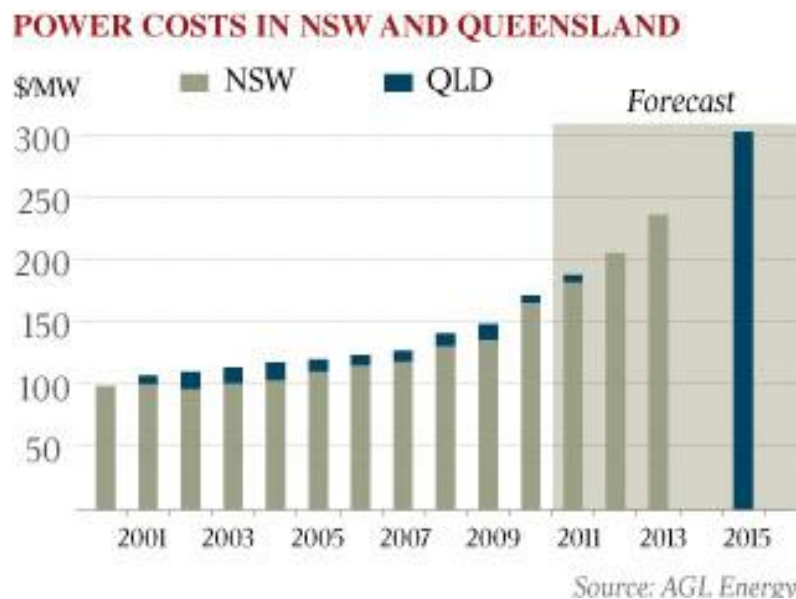

Figure 1: Electricity price increases in NSW and Queensland since 2004

The CRDC has previously funded the NCEA to conduct a desktop study of on-farm energy use for a number of case study cotton farms to understand the range, costs and contributions of energy use to cotton production and greenhouse gas emissions. The results from this work showed that energy use varies depending on the cropping enterprise and the farming system and that there are significant opportunities to reduce energy and costs. While direct on-farm energy use is a small component of the total energy used in the production of cotton lint, any savings made flow directly to the grower. The largest energy consumption in field to factory production of finished lint is the

fertilisers used in cotton production, which is the on-farm indirect energy use shown in figure 3, below.

A more detailed study undertaken by the NCEA on a large cotton farm in the Gwydir Valley identified significant reductions in energy resulting from the adoption of reduced tillage systems. The study showed that the adoption of a minimum tillage system had reduced energy costs (and greenhouse emissions) by 12% since 2000 and developing a “near zero till” system had the potential to reduce this to 24% less than 2000 energy costs.

It is evident from this work that there is substantial scope to improve energy use efficiency in cotton production systems, but to enable more growers to identify where they can improve, further development of tools, processes and human capacity is required.

Energy efficiency may be one of the fastest, cheapest and easiest ways to cut farmers energy expenditure and greenhouse gas emissions. Measuring or estimating energy use across an enterprise is the most important first step in this process because it identifies the major energy consuming operations across the enterprise and hence defines where the largest gains may be made. This same process can be used to assess the net worth of any changes.

2. Objectives

The aim of this project was to develop a cost effective process for assessing on-farm operational energy inputs with a particular focus on the Australian Cotton Industry. The specific objectives (milestones) of this work were to:

1. Develop a protocol for energy assessment
 - 1.1. Develop a common methodology for conducting energy assessments
 - 1.2. Develop a template assessment guide for energy assessment reporting
 - 1.3. Incorporate model reporting and assessment in software (i.e. EnergyCalc)
2. Compare practice based methodology with direct measurement
 - 2.1. Apply report and assessment methodology to determine direct energy inputs (on-farm)
 - 2.2. Conduct detailed energy measurements and compare with practice based methodology
 - 2.3. Determine the extent of data required for energy assessments and reporting
3. Quantify on-farm energy use for different farming operations
 - 3.1. Benchmark on-farm energy using standard assessment and reporting methodology
 - 3.2. Produce a library of on-farm energy use data for various farming operations
 - 3.3. Promote Energy Assessment and Reporting Tools
4. Evaluate energy use and GHG emissions for alternative production systems
 - 4.1. Characterise on-farm energy and GHGs for different production systems and locations
 - 4.2. Identify opportunities to reduce operational energy inputs and GHGs
 - 4.3. Produce Final Report

3. Protocols for Energy Measurement

Energy audits refer to the systematic examination of an entity, such as a firm, organisation, facility or site, to determine whether, and to what extent, it has used energy efficiently. An energy audit determines how efficiently energy is being used, identifies energy and cost saving opportunities and

highlights potential improvements in productivity and quality. The purpose of an energy audit is also to assess potential energy savings through strategies such as fuel switching, tariff negotiation and demand-side management (e.g., by changing to alternative farming systems).

In agriculture, the period of the audit is generally one year, which correlates to one cropping cycle.

An energy audit is undertaken as part of a broader plan to manage energy inputs on-farm. The objectives of energy management include:

- conserve energy inputs;
- reduce greenhouse gas emissions;
- achieve operational and cost efficiencies with improved productivity and profitability.

3.1. Energy Assessment Methodology

A first draft methodology was developed in August 2010 and lessons from this and other projects were incorporated into the final methodology. While there were several revisions the essence of the original method proved to be correct. A complete methodology has been developed for undertaking agricultural energy assessments and is contained in *Appendix A: A standardised practical methodology for benchmarking on-farm energy use and greenhouse gas emissions on cotton farms*. Thus, this methodology encapsulates lessons from this project and leverages the NCEA's background Intellectual Property (IP).

While there are some important differences (in the definitions of the levels of audit, reporting requirements, and other areas), this methodology draws heavily on the Australian / New Zealand Standard *AS/NZS 3598:2000 Energy Audits*. This standard was developed for the building industry and is recommended further reading. Consideration of the American Society of Agricultural and Biological Engineers standard *ANSI/ASABE S612 JUL2009 Performing On-farm Energy Audits* was made.

This methodology is designed for Australian cotton producers to:

- a) assist energy users to decide what level of audit is appropriate for their needs;
- b) provide a guide for energy users when commissioning energy audits;
- c) provide a uniform basis for preparing and comparing energy audit proposals;
- d) support the establishment of an energy management program by specifying pre- and post-audit activities for the energy user organisation;
- e) define suitable reporting requirements for the audit; and
- f) contribute to the quality of existing energy and other management systems, e.g. financial, environmental, operational or occupational health and safety management.

The process of improving on-farm energy use may start with an energy audit which benchmarks and establishes energy saving opportunities. The Plan-Do-Review-Improve (PDRI) approach (Figure 2) is commonly used in continuous improvement initiatives is often adopted for energy management.

There are a number of steps during the 'do' phase of an energy assessment regardless of what level of assessment is applied. The first phase is data gathering and this step takes some planning and logical thought as it is different in each situation. Suffice to say there is no standard approach, and

all cases require different assumptions. Following the data gathering step, the data is processed to calculate the required ratios (such as MJ/Ha) and charts to be presented in the report.



Figure 2: Plan Do Review Improve cycle

These steps are followed by the development of recommendations, reporting, and a review by the enterprise before the implementation of specific strategies and technologies, which are the 'REVIEW' and 'IMPROVE' stages respectively. This follows into 'PLAN' then 'DO' of the next audit.

Clearly, the integrity of this process is highly dependent on successful data gathering in the initial phase of the evaluation. The key to a successful energy audit is identifying prior to the season how energy use will be measured and recorded. It is important that likely error rates associated with any measurement methodology be considered and estimated.

3.1.1. On and Off-farm, Direct and Indirect Energy Use

Direct energy relates to the energy used for undertaking a particular farming task while indirect energy represents the energy embodied in the manufacture of farming inputs. On-farm and off-farm inputs provide a demarcation of where this energy use occurs. For example,

- On-farm direct inputs (e.g. fuel uses due to tillage and other field work)
- On-farm indirect inputs (e.g. manufacturing of fertilisers and on-farm machinery)
- Off-farm direct inputs (e.g. ginning and road transportation)
- Off-farm indirect inputs (e.g. manufacturing of processing machinery and storage facilities)

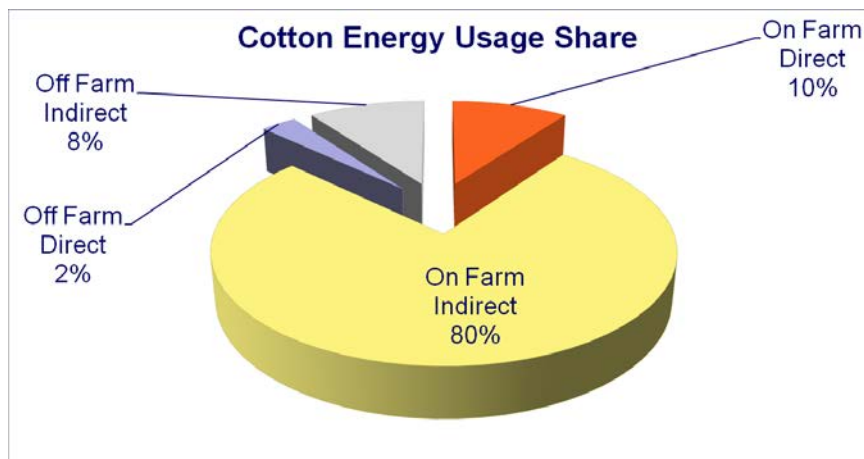

Figure 3: Total energy consumption in field to factory production of ginned cotton lint.

Fertilisers and Chemicals

A move towards minimum and no till systems in modern agriculture have increased a reliance on agrochemicals. Transgenic cotton has seen large reductions in the use of many cotton pesticides and an increased use of herbicides. The yields required to maintain the economic viability of modern production systems requires the use of synthetic fertilisers. Synthetic fertilizers and other agrochemicals require large amounts of energy to produce; they are indirect on-farm energy use and make up 80% of all energy use shown in figure 3, above.

As the production of fertilisers and chemicals are energy intensive, economics dictate that as the cost of energy rises, so too will the cost of fertilisers and chemicals. For example, one kilogram of nitrogen requires around 100 MJ to produce, which is equivalent to 2.6 litres of diesel, and emits around 1.3 kg CO₂-e into the atmosphere. For herbicides, one kilogram of active requires around 300 to 400 MJ (8 to 10 L diesel) to produce and emits between 3 and 15 kg CO₂-e. Insecticides consume 250 to 350 MJ per kg active (6.5 to 9 L diesel) and emit between 3 and 10 kg CO₂-e

An energy audit would typically investigate direct on-farm energy use (the consumption of diesel, ULP, electricity and other similar sources) and this project has been conducted in these terms. It is important to note that the same process could be easily extended to fertiliser, chemicals and other on-farm indirect energy use. This would allow the grower to also benchmark chemical and fertilizer use with others and to assess a net change in energy associated costs (as opposed to a shift sideways) for any change in farming systems.

3.1.2. Conversion Factors

Different sources of energy are measured in different units. Diesel, for example, is purchased in litres while electricity is purchased in kilowatt-hours [kWh]. Once an audit has collected totals for various energy sources, each of these must be converted to joules, or mega-joules, to derive total energy. Figure 4, below, provides standard conversion factors. In addition, each energy source will emit different amounts of greenhouse gasses, expressed as kilograms of carbon-dioxide equivalent [kg CO₂-e]. The embodied energy and greenhouse gas (GHG) per unit of energy source presented in figure 4, below, are those published by the Department of Climate Change and Energy Efficiency.

Source	Embodied energy		Greenhouse gasses	
Diesel	38.6	MJ/litre	2.68	kg CO ₂ -e/L
Biodiesel	34.6	MJ/litre	0.12	kg CO ₂ -e/L
B20	37.8	MJ/litre	2.17	kg CO ₂ -e/L
ULP	34.2	MJ/litre	2.29	kg CO ₂ -e/L
LPG	25.7	MJ/litre	1.54	kg CO ₂ -e/L
Electricity NSW	3.6	MJ/kWh	0.88	kg CO ₂ -e/kWh
Electricity Qld	3.6	MJ/kWh	0.86	kg CO ₂ -e/kWh
Aviation Kerosene	36.8	MJ/kWh	2.56	kg CO ₂ -e/kWh

Figure 4: Embodied energy and GHG emissions for different energy sources.

The third element of an energy audit is the cost of energy. The gross cost of each energy source should be taken from farm records.

3.1.3. Audit Types

Energy audits may be conducted with different levels of detail and these are discussed below. A user may decide to conduct any single level of audit or may conduct a level one audit and then progress to a level two audit and possibly to a level three audit. Each level of audit has its own time and monetary cost.

The level of audit will depend on factors such as

- The potential energy or energy cost saving strategies,
- The level of detail and accuracy required to evaluate proposed changes,
- The total annual energy cost,
- Size of the site.

Figure 5 summarises the various levels of an audit, the steps involved and how these fit into the PLAN-Do-REVIEW-IMPROVE cycle shown in figure 2.

An auditor may enter the process at any level. For example, a level one audit conducted in the first cycle might identify that gross energy use as high when compared to other enterprises. A level two audit, which itemises energy use for key processes, might identify savings in some areas and insufficient information in other areas. In a third iteration, metering can be installed to conduct a level three audit in certain aspects of the enterprise while changes are made to other areas of the enterprise. Alternatively, an auditor may go straight to a level two or even a level three audit.

A Level One, Overview Audit

A level one audit, sometimes called an overview, is simply the total energy consumption expressed per hectare and per unit of production. This is the simplest and cheapest form of energy audit. A level one audit involves collating all receipts for diesel, ULP, electricity and other energy sources to calculate total energy use via the conversion factors in figure 4. Similarly, all production receipts and records of area are collected.

A level one audit is straightforward where there is only one commodity produced. Often there is more than one type of production on the farm and a level one audit is not able to discern how much

energy went into each enterprise. For example, a cotton farm might also produce wheat. A level one analysis is unable to determine how much of the total energy went to cotton production (to give MJ per bale) and how much went to wheat production (to give MJ per tonne). In these cases, a level two analysis is performed and then amalgamated back up to a level one analysis. In this case, the level one analysis will have the same error as the level two analysis.

Level Two, Itemised Audit

Level two energy audits involve itemising the total energy used on the farm into energy used in each key farming operation. Ideally a level two audit will measure energy used in each operation over a considerable time period, such as a year. Energy use is itemised either from easily obtainable data or by estimation techniques. The purpose of a level two assessment is to identify energy saving opportunities and/or requirements for further investigation. It is primarily a desktop study and aims to achieve an accuracy of $\pm 20\%$.

Records kept at the fuel bowser which specifies date, machine ID and litres are an excellent resource to conduct a level two analysis. Other sources include electricity invoices for individual meters or the installation of sub-meters if electrical energy use is significant.

Where this information is not available, estimation techniques are used. This process usually involves considerable farmer interviews and is supplemented by any available fuel and electricity measurements.

Software calculators and tools are often employed in this step because detailed records do not always exist. Estimation techniques are difficult, time consuming and require expert knowledge. Estimation techniques introduce unknown errors via the assumptions made and are less precise than measured data. Tools such as EnergyCalc provide benchmark figures and in-built expert knowledge. Such tools streamline the process so that a novice user can quickly itemise energy use for their enterprise and provide information where no measured data exists.

Level Three, Specific Operation Audit

Level three energy audits quantify the energy usage during or within a specific operation. Typically, level three audits focus where the greatest energy consumption or greatest potential gains have been identified from a level two audit. This will usually involve a range of different sensors to measure the performance of the machine. Examples of sensors may include irrigation pressure head, engine RPM, tractor travel speed, torque, load and temperature. A data logger may be required to record the data for a considerable period of time. A level 3 energy audit may be necessary to certify a product/farming operation and to establish the energy-star rating and labelling scheme.

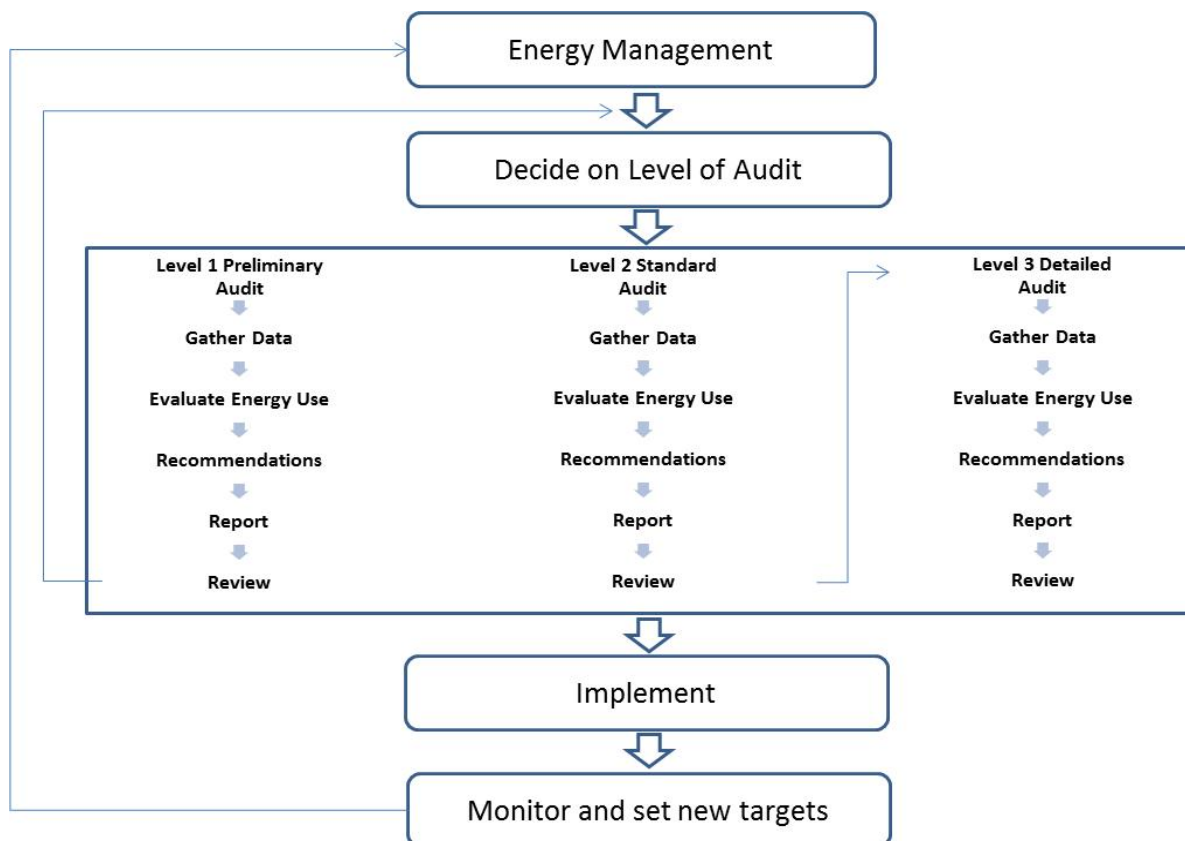

Figure 5: Energy assessment and management process

3.1.4. Measurement Accuracy

Accuracy is how close your measurement is to the actual value. How accurately you are measuring anything is a critical consideration. If we want to measure a variation or difference of $\pm 5\%$ then a measurement system of $\pm 10\%$ is not going to be adequate.

How close your answer is to the true value, or the accuracy of your measurements, will vary greatly. Some estimation techniques provide no way to estimate the accuracy of the result and are regarded as 'best-guess'. Where we measure physical quantities, diesel use for example, there are techniques to estimate how accurate our measurement might be.

The level of accuracy required from the audit measurement system compared to estimation techniques is discussed in detail in Section 5.4 *Energy Assessments, Accuracy and Reporting*. The important consideration is that we must be aware of how accurately our measurements are.

3.1.5. Assessment Reporting

Energy assessment reporting has been refined during the project. EnergyCalc reporting found in *Appendix E: EnergyCalc Report* contains all required information. A review of the reporting towards the end of the project has identified opportunities to stream line this report while still retaining the same level of detail.

3.2. EnergyCalc

Significant progress has been achieved with EnergyCalc since initial development of the model by Chen and Baillie, (2009). Other NCEA work has also contributed resources to assist with the

modification of EnergyCalc. This has resulted in an energy assessment tool that is directly applicable to cotton and generic to agriculture. This assists with benchmarking between industries. Further details can be found in *Appendix B: EnergyCalc Users' Manual*. and *Appendix C: EnergyCalc Information Sheet*. EnergyCalc can be found online at <http://kmsi.nceaprd.usq.edu.au/>

Changes to EnergyCalc include a modified report, which now includes i) summarised energy inputs ii) actual machinery / energy inputs and iii) performance indices based on production and area. Other functional changes include the ability to export data in an Excel (.csv) format for further analysis and reporting. NCEA software developers have also developed a Lite version of EnergyCalc (in a separate project) which resides on an iPad and is available from the Apple Apps store.

EnergyCalc is an online Energy calculation tool for agriculture and is part of the knowledge Management System for Irrigation (KIMSI) suite of tools. EnergyCalc is designed to:

- Assess direct on-farm energy use, costs and greenhouse gas emissions associated with diesel, petrol, LPG and electricity consumption.
- Examine energy use within a production system.
- Evaluate farming practices such as tillage, spraying, irrigation etc.

EnergyCalc is multi-crop software that allows for the user to input their production of not only cotton but wheat, oil seeds and any other crops. Each user has their own unique logon and can only see their own information, which is critical for trust and confidentiality of the tool.

Assessment

Create a new assessment by clicking the 'New' button below. If there are any existing assessments, they will appear, click on 'Select' to edit or view a particular assessment. If an assessment is no longer needed, click on the icon to delete.

New

Assessment Name	Year	Level	Type	Select
A. Farmer	2009	Level 2	Actual	
cotton with default value	2009	Level 3	Actual	
New assessment	2011	Level 2	Actual	

To add a crop/product to an assessment, first select an industry and then select it from the drop down boxes below. A new assessment can be created from an existing assessment by clicking the 'Copy Crops' button and pasting the crop list into the new assessment by clicking the 'Paste Crops' button. If a particular crop / product is missing from the drop down menu, make a request on the online ticketing system which can be found on the KMSI interface by selecting 'Ticket'.

Select Primary Indust | Select Crop/Product | Copy Crops | Paste Crops

Industry	Crop/Product	Description	Area (Ha)	Production	Unit	Select
Field Crops	Cotton	Irrigated with default val	458	8.42	bales/ha	

Figure 6: New assessment can be made using this online tool by simply clicking the 'new' button.

EnergyCalc is able to accept measured information, such as litres of fuel or kWh of electricity should that information be available. Importantly, EnergyCalc includes a calculator that uses default values to estimate energy use where detailed energy use is not always known, as is often the case.

Industry	Crop/Product	Description	Area (Ha)	Production	Unit	Select
Field Crops	Wheat		310.1	1550	tonnes	
Field Crops	Cotton	yield estimated	594.4	4065	bales	

Calculation

To add a practice to a crop, you will need to select a process, an operation and a practice. Then select an energy source. The cost of each energy source could be changed if you like. After selecting an energy input type, you can start to calculate. Click on to load second level calculators. Click to save or to cancel.

Choose Practice	Energy Cost	Energy input
Harvest	Diesel (litre) 1.18	Number of operation 1 Constant
Harvesting	Petrol (litre) 1.2	Diesel used per operation 26748 litre
Cotton Picker	Gas (litre) 0.3	Area 594.4 ha
Add new practice	Electricity (kwh) 0.1	Diesel used per ha 45 litre/ha

Practices

To remove a practice, click on at the beginning of the row. To modify the practice, click on

Practice	Energy Source	Energy Used	Standard Energy (GJ)	%	Cost (A\$)	%	Emission (Kg)	%
Bed Renovating	Diesel	6413.00 (litre)	247.54	41	7567.34	41	18597.70	41

Figure 7: EnergyCalc includes a calculator (circled) to estimate unknown values.

After completing the assessment, a report can be generated for one crop or all crops. The generated report calculates the energy, greenhouse gas emissions and costs for particular practices entered into the calculator. The report is also able to be exported to excel and other software via a .csv file.

		Root Cut	Diesel	410.65 (litre)	15.85	2	484.57	2	1190.89	2
		Ripper (Pupae Bust)	Diesel	2179.31 (litre)	84.12	12	2571.59	12	6320.00	12
Total		-	-	-	684.14	100	20914.15	100	51399.19	100

Report

To produce a report on the selected crop, click on 'report' button for PDF format or click on 'Export .csv' for CSV format. To include all crops in the report, use the other buttons named 'Export all crops .csv' and 'Report all crops.'

Data Confidentiality: Data recorded and maintained in this software is stored confidentially for the purposes of the user. This data may however be aggregated or reported in a format where the identity of individuals are protected from third parties.

Figure 8: EnergyCalc reporting options.

An EnergyCalc report includes the following sections:

- Machinery inputs i.e. tractors, stationary motors, pumps and vehicles
- Summary of energy use
- Performance indicators
- Energy and cost savings

The grower report attached in *Appendix E: EnergyCalc Report* provides the exact report format.

Importantly, EnergyCalc data can be aggregated to obtain industry averages. These industry average values are in turn used to improve the default values used in EnergyCalc.

3.2.1. EnergyCalc Lite

The NCEA has recently received funding from the CRDC to develop a version of EnergyCalc for mobile platforms (i.e. EnergyCalc Lite). EnergyCalc Lite is now the preferred mechanism to administer broader / ongoing benchmarking activities that would be captured in myBMP.

The newly developed software, 'EnergyCalc Lite' is congruent with the latest version of EnergyCalc; it includes essentially all of the functionality of EnergyCalc without the same level of reporting functionality. This tool is designed for use by the Cotton Industry Development and Delivery team and by farmers.

4. Case Study Methodology – Level One and Level Two Assessments

Seven key collaborators were established at the commencement of the project. Three of these were from previous projects which allowed these data sets to be carried into this project. The case study farms are based in New South Wales and Queensland. In New South Wales these include, the upper Namoi Valley (Breeza), lower Namoi Valley (Wee Waa) and the Gwydir Valley (Moree). In Queensland the sites include the Macintyre Valley (Goondiwindi), Darling Downs (Dalby) and Central Queensland (Emerald). The location of the collaborators is shown in figure9, below.



Figure 9: Location of collaborators.

The farms represent a mix of ownership and management types with some corporate farms, multiple farms under common ownership and larger and smaller owner-operator farms. Total irrigated area for the study is 15,332 hectares and using Cotton Australia's (2013) average farm size of 467 Ha this study represents a total of 33 average farms.

The 'Year' or 'Crop Year' reported in data and elsewhere in this report refers to the year in which the crop was harvested and all operations pertaining to the crop were kept with the crop. For example

for cotton, ground preparation may occur in July 2012, pre-watering in September, planting in October and harvesting in the following April 2013. All of these operations would be labelled as 2013. Wheat is generally simpler as all operations occur within a calendar year.

Site visits commenced in 2010 and continued throughout the project. Information was collated according to the methods described in Section 3. *Protocols for Energy Measurement*. A more detailed methodology can be found in *Appendix A: A standardised practical methodology for benchmarking on-farm energy use and greenhouse gas emissions on cotton farms*. Data has been obtained from a combination of detailed discussions with collaborators using a data collection template, developed for EnergyCalc and access to farm records.

Level One and Level Two analyses were conducted on all sites. Some Level Three analyses were conducted and these are discussed in Sections 4.1 and 5.3. To complete energy assessments to either a Level One or Level Two standard, all energy use and all crop production must be accounted for.

As part of the process of a level two analysis it is necessary to account for all energies used in all operations in the enterprise, including other crops. This is so the results of the level two analysis can be checked against the more reliable and known figures of energy purchases, derived from a level one audit.

Data for four of the case study farms was obtained from the farm management software PAM. In the initial stages of the project the PAM software was seen as being commonly utilised across the cotton industry. Towards the end of the project many of the collaborators were starting to move away from using the PAM software. Whatever the software platform, electronic records make analysis of energy use (or any other analysis) fast and effective.

It was noted that the PAM software was being used in slightly different ways by users. Some growers were using default machinery inputs costs / energy use; some farmers averaging seasonal energy use for different implements and operations while in one case the farmer was separating the tractor and implement in data entry to capture detailed information on energy use and costs (i.e. different energy use for tractor / implement combinations as opposed to different implements). This would appear to set a standard for best practice.

One farm recorded diesel used from the bowser and these records were used to attribute diesel use to individual operations. This method was quick and easy to compile.

4.1.Detailed Monitoring Methodology – Level Three Assessments

During the project different needs and opportunities arose for more detail energy assessments in tractors and pumping.

4.1.1. Tractor Monitoring

Level three tractor monitoring was performed during the project using commercial GPS-based tractor monitoring systems. Tractor investigations centred on John Deere's Green Star 2 (GS2) system. This system was not selected as such. Rather, it was that most machines in the study that were monitored used the GS2 system. Other manufacturers have GPS monitoring system which are practically the same and some third party options are available. Please refer to *Appendix F: Tractor monitoring and the ISOBUS standard* for general information on tractor monitoring.

Tractor data was obtained from two sources: John Deere (Walsh P., Pers. Comm.) and data downloaded directly from the machines owned by project collaborators. These data will be discussed in detail in Sections 4.1.1. and 5.3.1. Data was obtained for tractors, cotton pickers, sprayers and grain harvesters. Tractors are further divided into categories of operations (such as pupae busting, discing etc.). Data was collected from machines in Goondiwindi, Dalby, Emerald, Moree and Wee Waa.

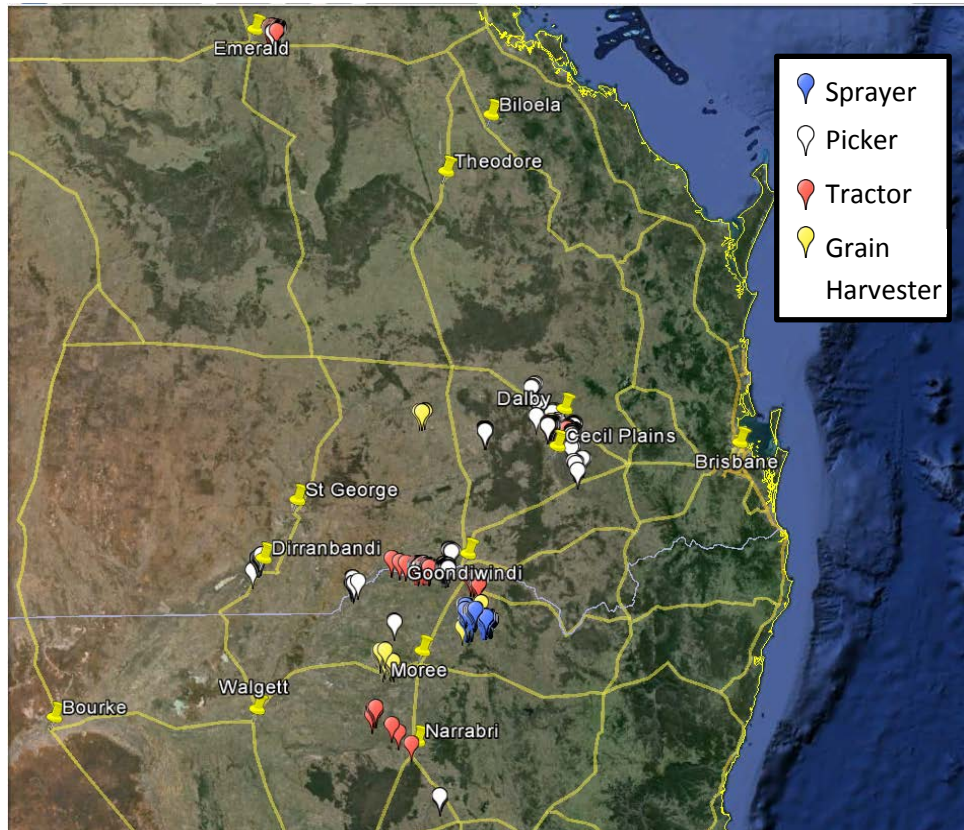

Figure 10: Location of John Deere proprietary data.

4.1.2. Pump Monitoring

The NCEA has developed a Pump Efficiency Monitor (PEM) to identify pump efficiency problems. The PEM consists of four types of electronic measuring sensors and data logging capability. This enables the continuous measurement of various pump variables to assess efficiency and monitor energy use during an irrigation season. Conducting a pump test will verify how the pump is operating at a single point in time. The ability to record an entire pumping event will highlight trends and provides information on how the pump performs across the entire operating range and thus how to improve the efficiency of the irrigation process. Fuel consumption of the diesel engine is measured via two McNaught fuel flow meters with a range of 15-500L/hr. These meters are installed on the inflow and return fuel lines and produce a pulse output equivalent to 2.5mL of diesel per pulse. Two types of instruments are used to measure the energy output of the pump. First are two WIKA pressure transducers a -1 to 0 bar rate. This requires an onsite calibration. All the measurements are recorded in a Campbell Scientific data logger and processed to determine fuel consumption/cost per mega litre per meter head (litres diesel/ML water pumper /m static head). The pump efficiency monitor contains telemetry equipment installed on the inlet and a 0 to 1 bar installed on the outlet. This will measure the total dynamic head (TDH) across the pumping system. The second is a Dalian Zerogo

ultra sonic flow meter used to measure water flow to allow access to the data where a 3G network is available. A battery was installed to ensure an adequate power supply to the PEM and access to the data. Battery charging is conducted via the 24V system on the diesel engine plus a 10W solar panel.

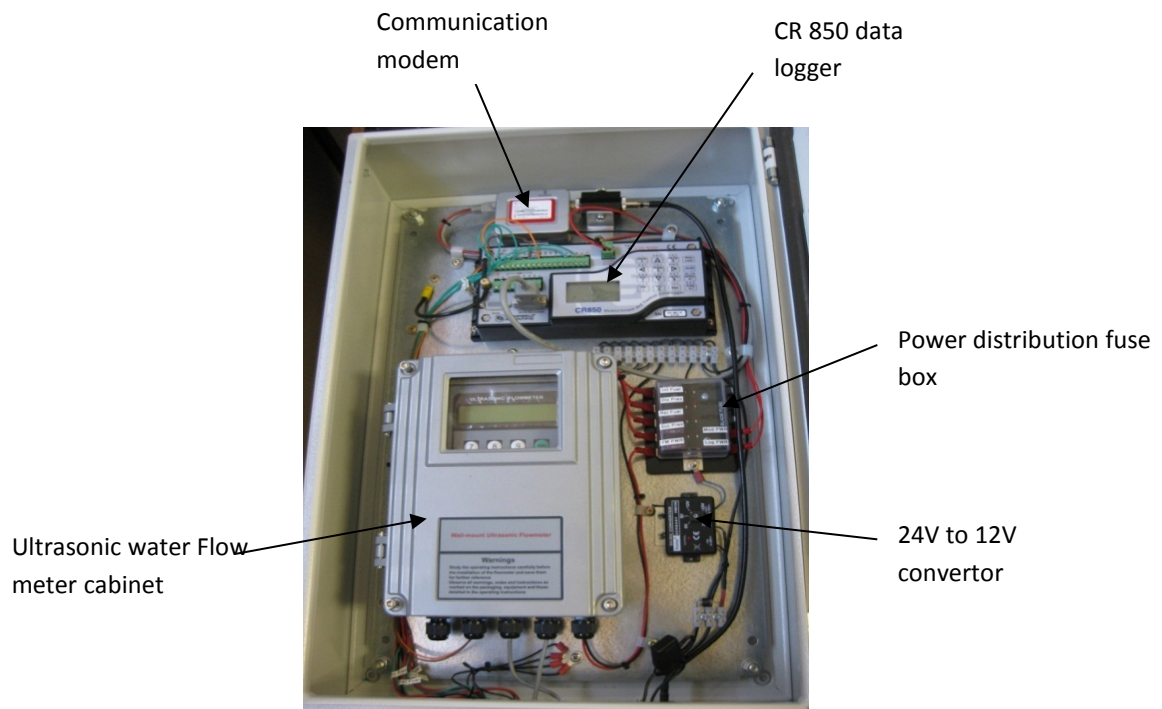

Figure 11: PEM unit key components

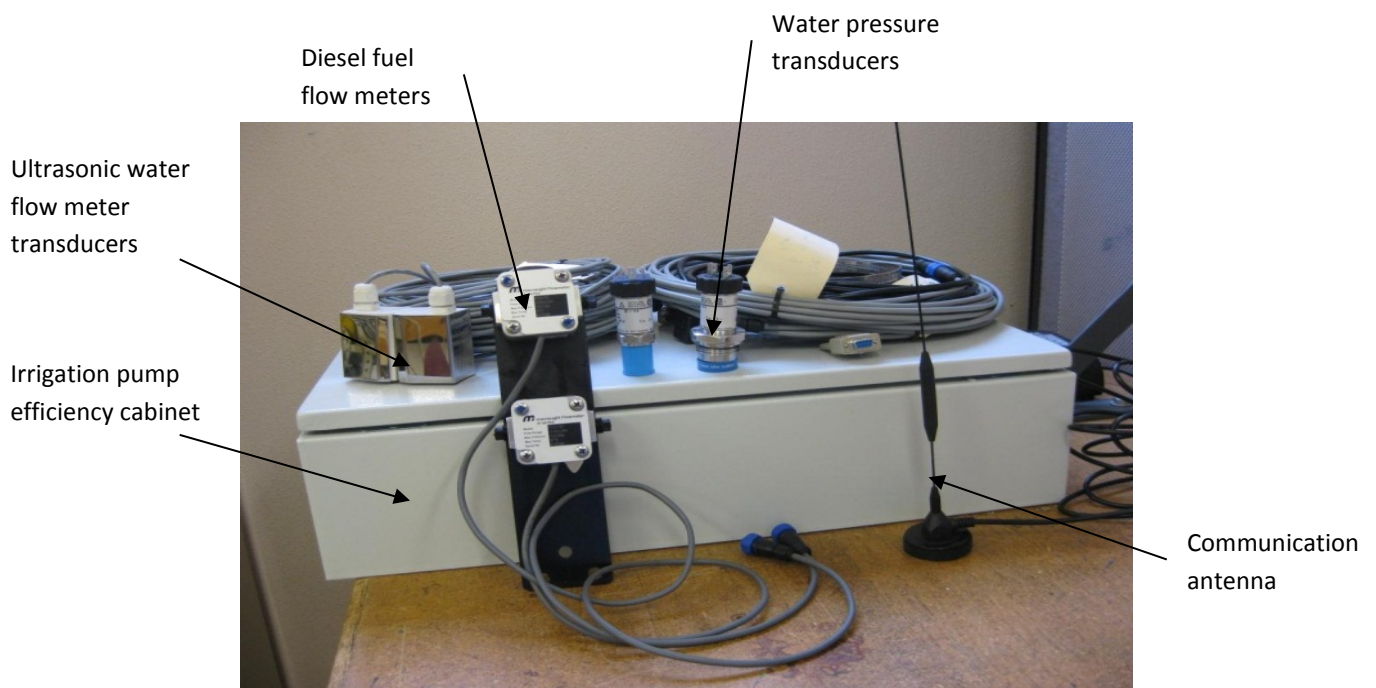

Figure 12: PEM unit sensor array.

The pump efficiency monitor was first trialled during the 2012/13 irrigation season on a cotton farm located at Goondiwindi, Qld. The PEM was installed on a Macquarie Centrifugal 26HBC-40 lift pump,

driven by a Volvo Penta TWD1211P engine. Data for one pumping event (12 days) was successfully obtained during this initial trial. This pump station is used to recirculate tail water and runoff water back into the main supply and to on-farm water storage. This data was analysed in the context of the relevant pump curve and compared to the corresponding fuel consumption to determine a combined efficiency of the pump and diesel engine. Recommendations to improve pump efficiency were then provided to the farm manager.

These activities were conducted in collaboration with Ms Janelle Montgomery (NSW DPI) and the CRDC funded project “Promoting Water Smart Infrastructure Investment in NSW”. This provides synergies with the current work under NEC1101 and has created an opportunity to undertake a broader energy assessment approach to a particular focus on irrigation, which the NCEA can facilitate. This logging system was being duplicated for NSW DPI for their work in the cotton industry.

5. Energy Benchmarking Results.

Operation energy use has been benchmarked for the cotton industry using standard methodology described in previous sections and is presented below in this section

5.1. Benchmarking Energy Use Using Standard Assessments – Level One Results

	Energy (GJ/Ha)	Energy (GJ/Bale)	GHGs (kg CO2/Ha)	GHGs (kg CO2/Bale)	Energy Cost (\$/Ha)	Energy Cost (\$/Bale)
Irrigated	10.9	1.18	1,091	119	310	34
Supplementary	3.6	0.43	247	30	101	20
Dryland	3.1	0.71	212	49	87	12

Figure 13: On-farm energy use benchmarks for cotton production

Farming System	Bales /Ha	GJ /Ha	GJ /bale	Kg CO2-e /Ha	Kg CO2-e /bale	\$/Ha	\$/bale
Dryland	4.3	1.6	0.4	114	27	47	11
Dryland+1 irrigation	8.2	3.6	0.4	247	30	101	12
Irrigated on Wheat	3.8	16.2	4.3	1,948	513	463	122
on wheat single skip	8.6	4.0	0.5	276	32	113	13
on cotton single skip	7.1	4.3	0.6	302	42	124	18
on cotton single skip	6.3	2.6	0.4	178	28	73	12
on cotton	8.9	2.6	0.3	180	20	74	8
60" Irrigated	9.0	6.1	0.7	427	47	175	20
30" Irrigated	10.3	9.2	0.9	641	62	263	26

Figure 14: On-farm energy use benchmarks for different farming systems

5.2. Quantifying Individual Operations – Level Two Results

Dividing the results of all level two energy audits for irrigated cotton production into the various phases of production the following figure was derived.

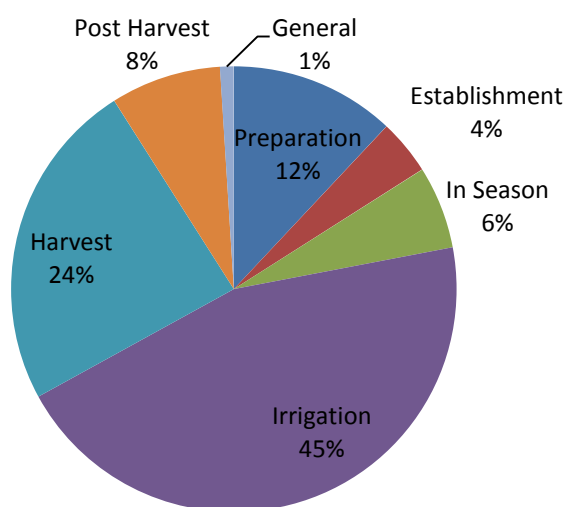

Figure 15: Average distribution of energy use for irrigated cotton production

		Standard Energy (GJ/Ha)	Standard Energy (GJ/Bale)	GHGs (kg CO2/Ha)	GHGs (kg CO2/Bale)	Energy Cost (\$/Ha)	Energy Cost (\$/Bale)
Preparation	12%	1.2	0.1	156.5	18.8	37.0	3.7
Establishment	4%	0.4	0.0	52.2	6.3	12.3	1.2
In Season	6%	0.6	0.1	78.3	9.4	18.5	1.9
Irrigation	45%	4.6	0.5	586.9	70.3	138.6	14.0
Harvest	24%	2.5	0.3	313.0	37.5	73.9	7.5
Post Harvest	8%	0.8	0.1	104.3	12.5	24.6	2.5
General	1%	0.1	0.0	13.0	1.6	3.1	0.3
Total		10.3	1.1	1,304.3	156.3	308.1	31.1

Figure 16: Average distribution of energy use for irrigated cotton production

5.2.1. Irrigation Energy

Irrigation typically accounts for 40 to 60% of all direct, on-farm energy use. Those farms which sourced bore water used an average of 9.6 GJ/Ha in water pumping. Those farms with scheme water supplied to the farm used 2.5 GJ/Ha in water pumping while river irrigators used an average of 5.3 GJ/Ha in pumping.

5.2.2. In-field Operations

A library of on-farm energy use for various farming operations, presented in figure 17 has been produced using benchmarked data for the cotton industry. The column 'AVG' contains the numerical mean of all energy used. The columns '95% CI' represents the range of values that will be encountered 95% of the time. The columns 'MIN' and 'MAX' are the minimum and maximum

values, respectively, in the data set. The column 'COUNT' is the number of records obtained for each operation; the higher the count, the more reliable the data.

Using the conversion factors stated in figure 4, these diesel consumption data have been converted into MJ per hectare and GHG emissions, CO₂-e per hectare.

	Fuel Use [l/Ha]					Average MJ/Ha	Average kg CO ₂ -e/Ha	
	AVG	95% CI		MIN	MAX			COUNT
Bed forming	8.3	6.6	10.0	6.0	12.0	27	320	22
Boll Buggy ²	4.0	2.3	5.7	3.0	6.0	3	154	11
Boom Spraying ¹	0.7	0.5	0.9	0.5	1.6	100	27	2
Cotton Harvesting combined ²	40.0	35.7	44.3	35.0	45.0	12	1544	107
Cotton Picker ^{2,3}	33.0	30.4	35.6	29.0	36.0	7	1274	88
Discing	9.5	6.9	12.1	4.5	14.0	12	367	25
Fertiliser bar	5.9	4.1	7.7	4.1	7.9	5	228	16
Fertiliser spreader	2.3	1.1	3.5	0.6	3.5	13	89	6
Inter-row Cultivating	5.1	4.8	5.4	5.0	6.0	9	197	14
Levelling	44.0	22.0	66.0	29.0	60.0	2	1698	118
Lillistons	6.0	-	-	6.0	6.0	1	232	16
Module Builder ²	3.1	3.1	3.1	3.1	3.1	2	120	8
Mulching	7.7	7.2	8.2	6.0	8.1	12	297	21
Planter	3.5	2.6	4.4	1.7	4.4	11	135	9
Ripping ¹	10.0	7.3	12.7	6.0	14.0	22	386	27
Roller ¹	3.1	1.5	4.7	1.7	7.9	18	120	8
Root Cutting	3.4	1.0	5.8	2.0	8.0	15	131	9
Rotabucks ¹	0.4	0.0	0.8	0.1	1.1	6	15	1
Shielded sprayer ¹	2.3	1.2	3.4	1.0	3.5	6	89	6

1. Includes all crops
2. Figures do not include any round bale harvesters and are for traditional harvesting.
3. Numerical difference of total less boll buggy and module builder.

Figure 17: Library of Fuel Use [litres/Ha], average energy use [MJ/Ha] and average greenhouse gas emissions [kg CO₂-e/Ha] for various cotton farming operations

5.3. Level Three Assessments Results

The results of the level three assessments are presented herein and are congruent with methodologies presented in Section 4.1 *Detailed Monitoring Methodology – Level Three Assessments*.

5.3.1. Tractor Monitoring

Data was obtained from two sources: Downloaded from the project co-operator's Greenstar machines and from John Deere directly. The Greenstar data was downloaded from the machines and saved to a laptop; John Deere's APEX software was used to convert the data into an EXCEL compatible .csv format. While this is possible to do using PAM software, the APEX software was preferred as it retains client, farm, field and operation data in the file whereas PAM does not. All data was processed in the MATLAB software.

Access to the Electronic Controller Units (ECUs) and therefore the fuel and other data on John Deere's machines comes in three levels:

1. Farmer level. The level of access allowed to a farmer or other user as defined in the Users' manuals for GreenStar and Apex. There are no instructions for setting the machine for storing persistent data.
2. Dealer level. There are certain keys, which can be pressed for prolonged periods, and sequences of key presses which allow dealers' access to different ECUs on the machine for configuration and calibration.
3. Factory access. Advanced configuration of ECUs performed by the factory is the highest level of access anyone can obtain.

The NCEA obtained factory access data directly from John Deere. These data sets are complete records and include turns, moving between fields and all other fuel use.

The data presented in figure 18, below is data collected via the GreenStar systems during the project. 'Mean fuel Use' is 'average fuel use' in layman terms. The 95% Confidence Interval provides the range of values in which the estimated prevalence will fall 95% of the time. In other words, while there are exceptions, fuel use will generally be between these limits. Count refers to the number of times this activity was measured. For convenience, corresponding fuel use figures from Figure 17 in Section 5.2.2 have been repeated in the 'L2 benchmark' column.

While the GreenStar system initially appears highly configurable there are limitations as to how fuel use data is stored. By comparison between figures 17 and 18, it can be seen that the GreenStar system underestimates total fuel use. Operations with low field efficiency, such as picking, have a large difference while operations with a high field efficiency, such as discing, have a much smaller difference.

The primary limitation of the GreenStar systems is that fuel use at the ends of the field is not recorded. Also fuel use is not recorded where machines stop in the middle of a run or for any other reason. A single point observation for one turn in a JD 8345RT was that it took 21 seconds to complete a three-point turn at the tail-drain end, at a fuel burn rate of 18.5 litres per hour. Other measured data, including turning at the headlands show that that turn times typically range from 20 to 50 seconds, depending on the turn and the field conditions.

activity	Mean fuel use (l/ha)	95% Confidence Interval		Count	L2 bench mark
Bed forming	6.1	4.9	7.4	1	8.3
Centre Busting	6.5	4.3	9.2	23	-
Cotton Picker	21.8	17.2	26.9	278	33
Cultipacking	2.3	2.0	2.7	27	-
Discing	9.6	8.6	10.7	23	9.5
Grader Board	3.4	2.9	3.8	9	-
Grain Harvest	5.6	2.8	8.1	29	-
Ripping	24.5	19.7	29.9	40	10
Rolling Cultivator	2.5	2.2	3.0	21	-
Side Busting	14.4	10.8	18.7	90	-
Spreading Fertiliser	1.1	0.8	1.3	35	-

Figure 18: Machine fuel use obtained from GreenStar systems

Depending on row length and other factors, time taken in tractor operation for turning at the ends of the rows and other activities such as moving can vary widely but typically accounts for between 10% and 20% of total time, with 12% being a nominal value. Because the fuel burn rate is lower while turning, travelling and so on, these activities account for only 4 to 8% of total fuel use, with 5% being a nominal value. Thus Greenstar systems typically account for around 95% of fuel used in tractor operations. However these values vary according to the operation. Pickers have a lower ground speed and spend more time in the row for each turn so the portion of time spent turning is less of the total time; they require more servicing and moving time. Greenstar systems will typically not account for 10 to 17% of a picker's time and 4 to 7% of a picker's fuel (11% and 5% respectively are nominal values). Fuel for ancillary equipment is of course not captured by the Greenstar system. Conversely, sprayers, which have a high ground speed, spend less time in the row for every turn and also have high servicing and moving requirements. Greenstar systems would typically not account for 35 to 50% of total time and 20 to 30% of fuel; 40% and 25% are nominal values for time and fuel respectively.

In general, Greenstar accounts for more of the total fuel used in operations that have a high field efficiency, such as tractor operations, and less fuel for operations with a low field efficiency, such as spraying. Greenstar and other on-board fuel monitoring devices are useful in itemising total fuel use within the limits discussed above. Other systems have come onto the market, such as the JDlink tools. It is understood that this system, which has ongoing licencing and call costs, provides fuel use divided into 'idle', 'transport' and 'working' and should provide total fuel use. Fuel is also reported under the headings of 'today', 'yesterday' and 'last 12 months'.

While GreenStar systems have limitations in providing total fuel use (and are therefore not directly comparable with benchmark data) they do provide a wealth of detail within a field. Specifically, the GreenStar system with the APEX software provides a spatial map of fuel use. Fuel use maps include

real time performance of how the machine interacts with the environment such as wet soil versus dry soil, compaction and so on.

Below is an aerial photo and a fuel use map of a spreader operation in the same field. The darkest blue refers to the lower limit of the fuel use, which is 1.1 litres per hectare. This scales up to the darkest red, which relates to 2.4 litres per hectare. The map was created using the straight A-B lines in August, 2011. While this field does not represent a typical cotton field it is useful to show how complex a fuel use map can be.



Figure 19a: Aerial photograph of a field in Northern New South Wales

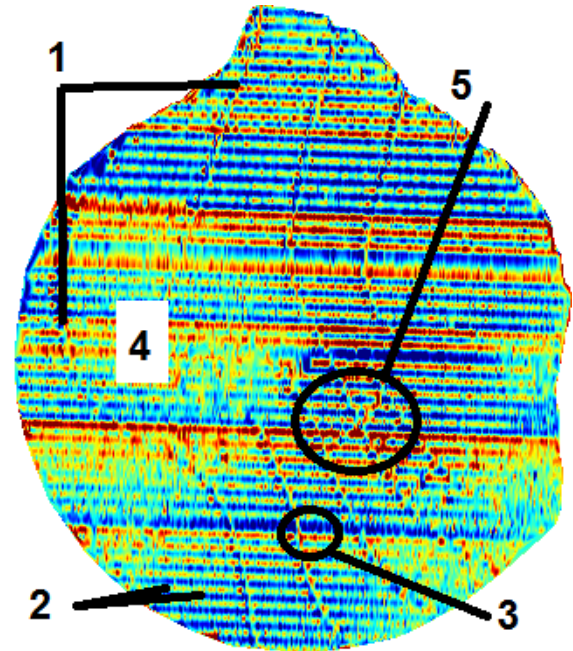

Figure 19b: A fuel map of the same field with 5 different factors identified affecting fuel consumption. The factors are contour banks (1), slope (2), weight of the spreader (3), soil type or steepness (4) and compaction (5).

There are a total of five factors relating to fuel use apparent in this map.

1. Contour banks are clearly visible. In fact, the uphill and downhill slopes of each bank can be discerned.
2. There is a slope on the field with the right of the image being higher than the left. The fuel map shows alternative stripes of dark blue (low fuel use) then yellow/red (higher fuel use) consistently across the field. The blue stripes are when the spreader is travelling downhill (from right to left) and the stronger colours were uphill passes.
3. There are six distinct bands that have a dark red at the top and graduate to a blue and these are congruent with the spreader starting full and gradually emptying.
4. The area on the fuel map surrounding the label '4' is generally more yellow as is a smaller area of the lower right of the fuel map. This is contrasted by a ridge of blue running through the middle of the map. This could correspond to a different slope,

terrain, soil type or soil moisture. The exact reason would need more information to identify. The pertinent point is that the fuel map identifies this trend.

5. The fifth factor is difficult to see at this scale but is discernible through very close inspection. When the image is magnified it is easy to see the wheel tracks of the centre pivot.

Importantly, the fuel use map

- shows wide variation of fuel use within a field, and
- provides high resolution data

The GreenStar data is able to provide more information than fuel maps. The following ground speed information has been collated from GreenStar data.

Operation	Speed km/h	Swath Width meters
Mulching	8 to 14	8
Root cutting	Up to 30	12
Mulching and Root cutting	8 to 14	4
Fertiliser spreading	12 to 14	12
Side busting	6 to 8	6
Offset discing	8 to 10	12
Bed renovation	10	12
Fertilising	8 to 10	12
Rolling Cultivation (Lilliston)	10	12
Cultipacking	10	12

Figure 20: Ground speeds derived from GreenStar data

Importantly, GreenStar and other GPS systems meet growing management needs.

5.3.2. Pump Monitoring

Figure 21, below, shows water flow, total dynamic head and diesel consumption data collected with the PEM unit during a single pumping event conducted between 27th of January 2013 at 12:30pm and the 7th of February 2013 at 5:30pm. The purpose of the pumping event was to fill an empty 1800ML ring tank from available flood waters as quickly as possible after a 250mm rain event.

At the start of the pumping event, the level of water below the pump was at the maximum flood level while the discharge level was at a minimum (as the on-farm water storage was empty). At this time, TDH was 3.0 meters, which was all suction head. The discharge to the empty reservoir is actually below the pump. At this point, engine speed was set to 1,800 RPM, corresponding to a pump speed of 630 RPM. A water flow rate of 5.8 ML/h was achieved with a net fuel consumption of 45 L/hr. Severe cavitation was detected in the pump at this time; Figure 22 shows that this duty point is off the pump curve.

The engine was run at 1,800 RPM for the entire event. The water level below the pump did not change significantly during the pumping event. At the conclusion of the pumping event, the storage was at maximum capacity and TDH increased to 7.0 meters, water flow rate reduced to 5.0 ML/h, while fuel consumption steadily increased to 49.0 L/h.

Figure 22 shows the operating range of the pump over the pumping event as described above. The points A and B are plotted the pumping event. This duty range produces very high levels of cavitation at such low TDH levels.

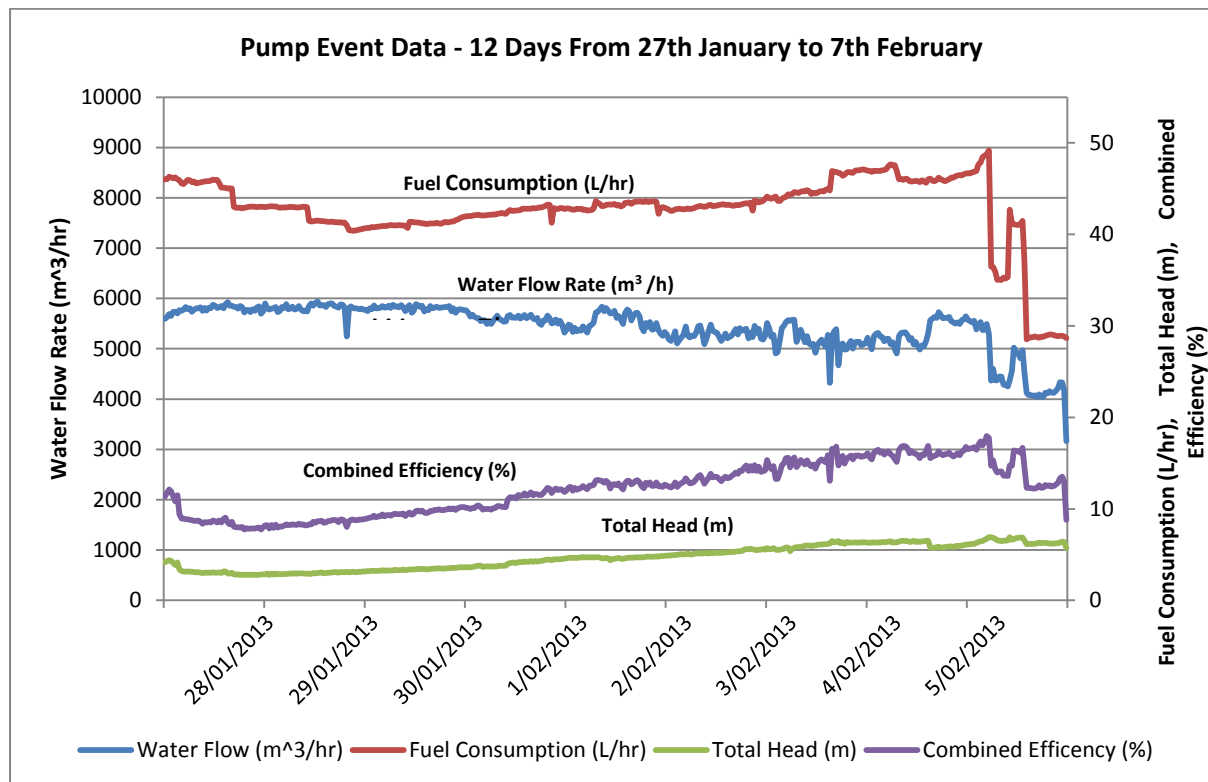

Figure 21: Water flow rate, fuel consumption and total dynamic head data collected over a single pumping event used to calculate combined engine and pump efficiency.

From the data gathered over the pumping event, fuel consumption per mega litre per meter head reduces from a maximum of 2.70 L/ML/m head at the start of the event to a minimum 1.04 L/ML/m head, which occurred at the end of the pumping event. The decrease in fuel consumption and increase in combined efficiency are displayed in Figure 23.

A comparison was made by reducing engine speed from 1,800 RPM (630 RPM pump) to 1,550 RPM (pump 550 RPM) to compare fuel consumption between the two operating speeds, this corresponds to points C and D in figure 22. It was thus determined that reducing the engine RPM also reduced the fuel consumption to 25 L/h and had a negligible effect in water flow rate reduction. The decrease in pump speed has reduced the cavitation improving mechanical wear and decreasing energy consumption.

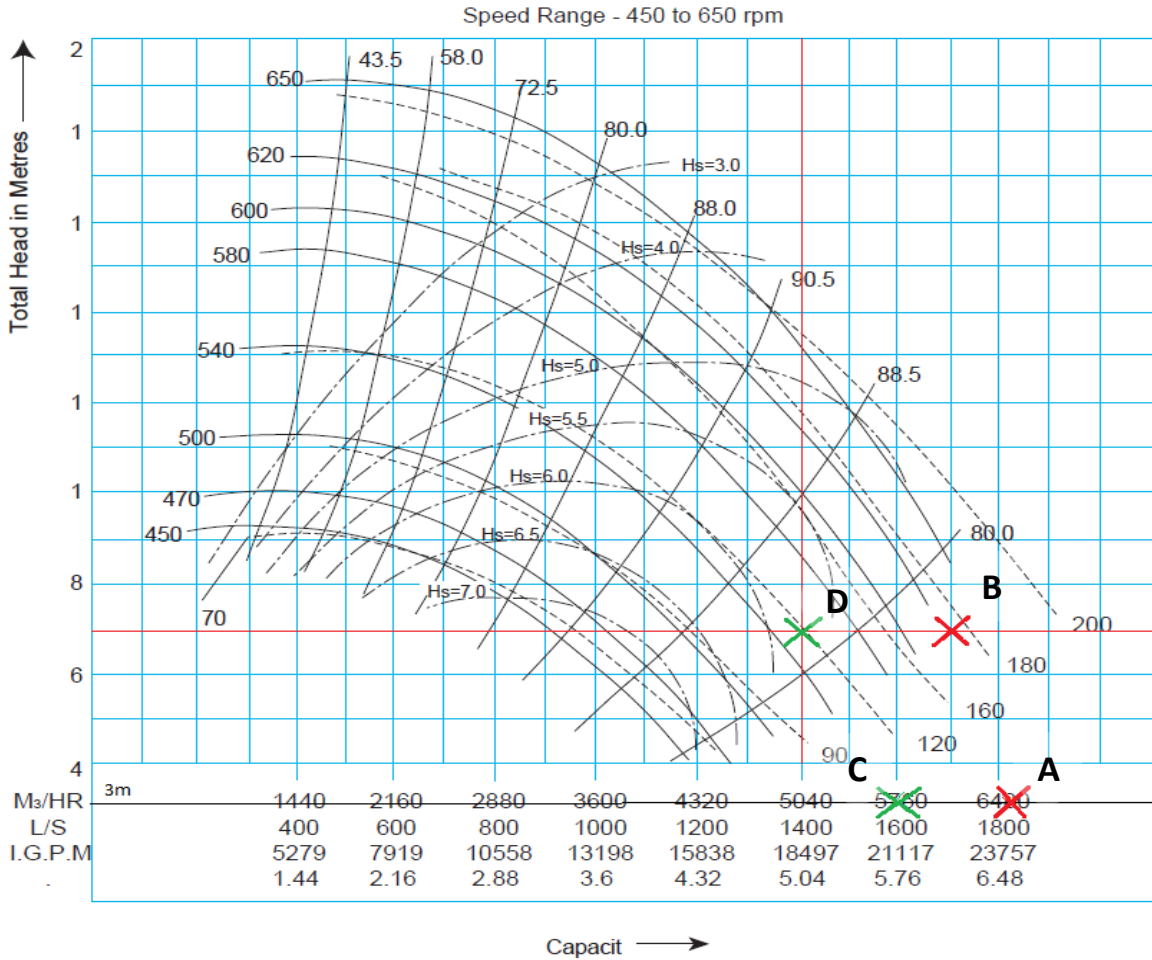

Figure 22: Pump operating duty points. A-B indicates TDH and RPM, C-D indicates TDH and water flow rate.

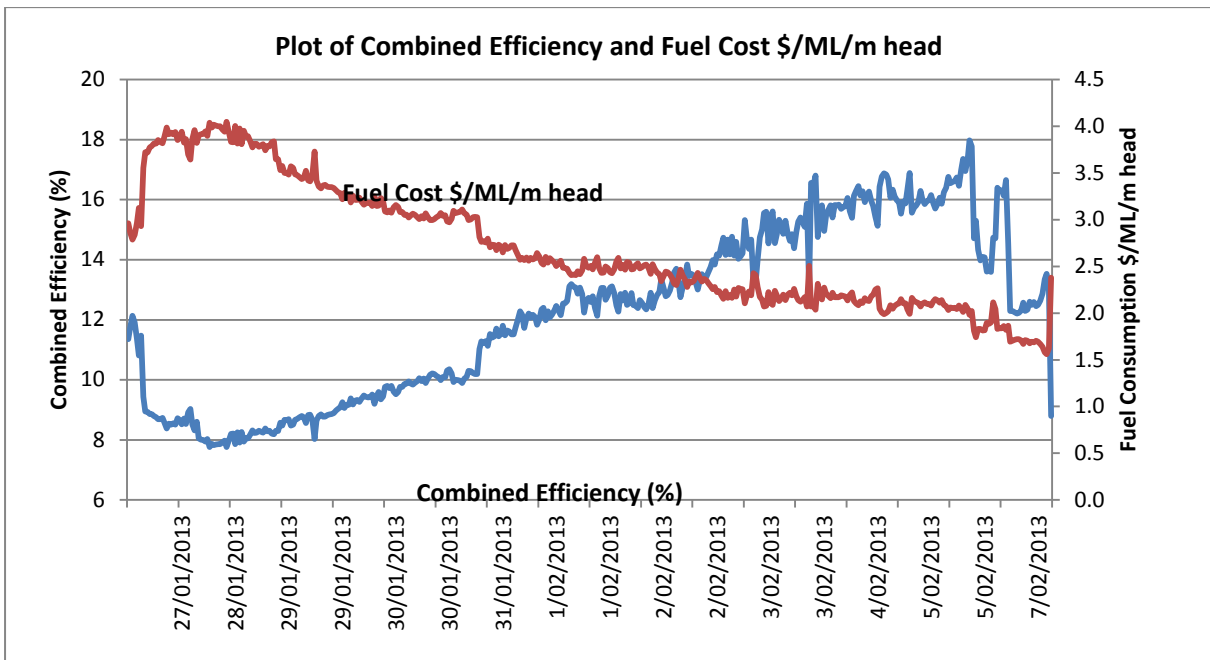

Figure 23: Combined Efficiency and Fuel Consumption /ML/m of lift

The grower kept fuel use records but had no records of engine hours. The PEM confirmed fuel use of standard practice of 49L/h. This was less than that estimated by the grower. The cost benefit analysis performed indicates a 44% efficiency gain by reducing the engine from 1,800 RPM to 1,550 RPM. The indicative cost saving will vary depending on the number of operating hours for the pump station. Figure 24a shows pump savings based on a typical annual pumping duty of 1,000 hours per annum.

The trial of the PEM has indicated that large energy and cost savings are achievable. The trial highlights the importance to test each individual pumping set-up to identify the optimum operating point to achieve maximum efficiency. Significant savings are possible for individual operators and the industry collectively.

Consumption		
Existing consumption	45,000	L/year
Proposed consumption	25,000	L/year
Efficiency gain	44	%
Energy Costs		
Assumed diesel costs	\$ 1.10	Per Litre
Existing diesel costs	\$ 49,500	per year
Proposed diesel costs	\$ 27,500	per year
Annual saving	\$ 22,000	per year

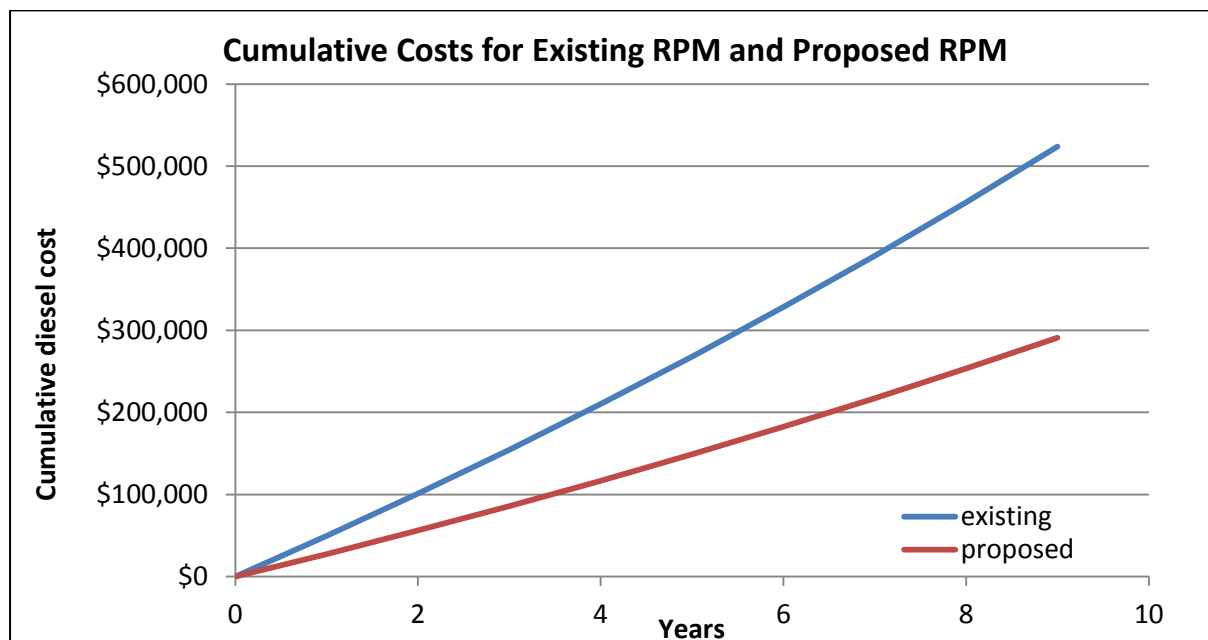

Figure 24a and b: Cost Benefit Analysis reducing from 1800RPM to 1550RPM.

5.4. Energy Assessments, Accuracy and Reporting

To compare energy assessments based on various sources of information, fuel use data was assembled from each of the case study farms and energy assessments were conducted in parallel using a practice based methodology. A practice based approach uses industry / published values to determine on-farm energy use via a record of machinery operations. The main benefit of a practice based assessment is the non-reliance on detailed monitoring and data collection; presumably at the expense of accuracy.

Energy use data obtained from all collaborating farmers was usually measured energy use. Where this was not available, estimations were made using enterprise specific default values. Measured fuel use data was obtained from 2 of the collaborating farmers and was based on information recorded from tractor performance monitors and fuel use recorded for various machinery operations. Enterprise specific default values for fuel use were obtained from 3 sites and largely based on historical measurements that had been undertaken to establish rules of thumb. Calculated fuel use was determined for 1 site and was based on machinery specifications and performance (i.e. engine power, ground speed, engine load, field work rate etc.). Preliminary results indicate that the percentage difference between measured results and practice based (default) results was within 10%. This indicates that a practice based methodology is potentially highly effective in quantifying on-farm energy, however further work is required to qualify this result.

In particular it was noted from this analysis that there is limited data on fuel use for cotton harvesting operations (i.e. cotton picking, boll buggies, and module builders). In response a number of collaborating farmers have recorded detailed energy use data for harvesting operations. This will provide a better understanding of the energy use associated with harvesting. The data currently being collected will also provide a comparison of conventional harvesting systems with the new round bale system.

Level one analyses had an error rate of 5% of total energy in each case study. This error rate was derived as the sum of the errors associated with the measurement of individual energy inputs, production and area, as discussed below.

Total diesel consumed in the season is assumed to be equal to total diesel purchased in the season, which is a correct assumption except for variances in opening and closing stocks. Total storage volume was typically 3% of total purchases and this was taken to be the error associated with the measurement of diesel use. If opening and closing stocks of diesel are measured (that is, tank volume is measured via the dip-stick) annually, these errors become negligible; less than 1%.

Unleaded petrol (ULP) typically accounted for 5 to 15% of total direct energy use and was treated in the same manner as diesel. Errors due to opening and closing stocks of ULP were always less than 1% of total energy.

Electricity use, which is typically 5% of total energy, is a small part of the total energy and is accurately metered by the supplier. Electrical energy use was taken from invoices and was assumed to add a negligible error to the measurement of total energy.

Farm production records are derived from quantities that are reliably measured at the delivery point such as tonnes of grain and kilograms of greasy wool, which are both known to have a measurement

accuracy of 0.2%. Production areas are generally derived from knowledge of paddock dimensions, hectare meters on various machines and GPS and other methods. An error rate of 1% was assumed for the measurement of farmed hectares.

Where there is more than one product, as in a typical cotton / grain production system, energies were accounted for using a level two analysis and amalgamated back up to level one information.

Measurement systems need to provide enough accuracy to measure the proposed change. Evaluating an LPG injection system in a pump motor, for example, will require measured fuel consumption and mega litres pumped for the truck before and after the conversion.

Benchmarking (between seasons and between farms) offers known benefits to farmers. Accounting firms typically offer benchmarking services for financial information and may have a significant role to play the energy benchmarking process. Alternatively, estimation tools, such as EnergyCalc provide reasonable guidelines.

Using a meter on the fuel bowser and a logbook to Account for diesel use provides a high level of accuracy and would be suitable for evaluating changes that require the energy consumption to be measured for a particular machine, such as in auto-steer or LPG injection. This method provides errors around 5% without tank volumes and around 1% with opening and closing stocks.

6. Energy Use and GHG Emissions for Alternative Production Systems

6.1. Life Cycle Energy Use

Cotton production, that is production of ginned cotton ready for transport to textile mills, requires a lot more total energy than is used directly on-farm. Figure 25, below, shows the results of a study that measured energy use from initial production through to finished product. Off-farm direct energy use is that energy associated with cotton transport ginning. Off-farm indirect energy use is that energy associated with the production of manufacturing and transport equipment.

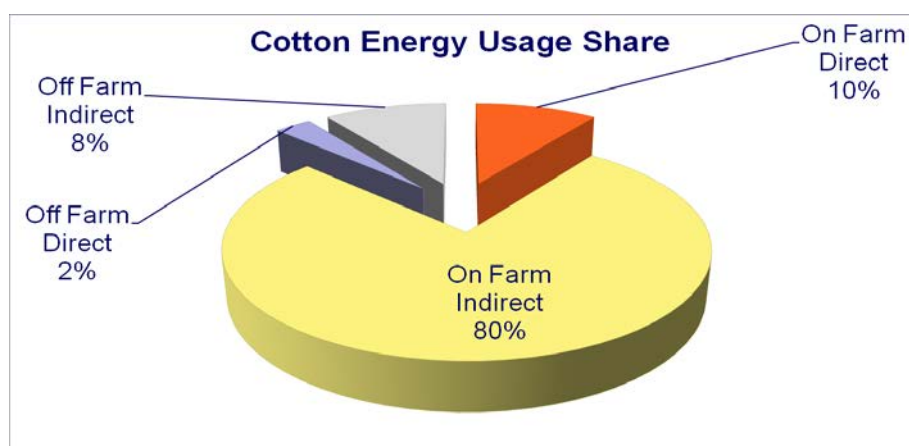

Figure 25: Life cycle energy use for the production of ginned cotton lint. Eady (2012).

Because cotton is a high-input crop, on-farm indirect inputs have the most significant contribution of all energies used in the production of finished cotton lint. On-farm direct inputs are predominately

fertiliser and chemicals, which are both energy intensive to produce, these can account for around 70% of total energy used in cotton production.

This illustrates that although the changes in the direct energy use and also the farming system can have a significant effect for the farmer, they may have little effect in an overall Life Cycle Assessment (LCA) in the production of cotton lint.

6.2.Characterising On-farm Energy Use and GHG Emissions for Different Production Systems and Locations

Energy use varies significantly for different cotton production systems and in different locations (due to inherently different circumstances). Generally, the majority of energy use on farm is associated with irrigation followed by harvesting. To explore the dynamics of on farm energy use, three scenarios were examined, (based on real data) that focused on irrigation and harvesting practices. Scenarios were built on practices / energy inputs recorded on 4 farming enterprises including 2 in the Namoi Valley; 1 in the Gwydir Valley and 1 in the Macintyre Valley. From these enterprises 8 farming examples were developed around the following 3 scenarios:

1. Ground water (Farm#1) vs. surface water irrigation (Farm#2) - Namoi Valley
2. Reduced irrigation (Farm#3; Farm#5) vs. full irrigation (Farm#4; Farm#6) – Gwydir Valley
3. Conventional harvester (Farm#7) vs. roundbale harvester (Farm#8) – MacIntyre Valley

By undertaking a standard energy assessment (level 2) on each of the farming examples identified, the following results were observed:

Ground water vs. surface water irrigation

Electricity for irrigation ground water pumping at Farm #1 makes up 72% of the total on-site energy use (13.4 GJ/ha). In comparison, Farm #2 which has similar farming operations to Farm #1, is irrigated by river pumps. As a result, electricity used for water pumping has been reduced to 4.3 GJ/ha, or 44% of total on-site energy use (9.56 GJ/ha).

In relative terms, the total on-site energy use is reduced by 29% (from 13.4 GJ/ha to 9.56 GJ/ha). Carbon emissions are reduced by 32% from 2075 kg CO₂/ha to 1408 kg CO₂/ha.

Reduced irrigation vs. full irrigation

Farm #3 is a low input farming system which is primarily based on supplementary irrigation water supply (4.27 ML/ha) and minimum tillage farming practices. As a result Farm #3 consumes 8.1 GJ/ha, which is considerably lower than Farm #1 and #2. The associated GHG emission is also reduced to just 566 kg CO₂/ha. Farm #4 has an identical farming system, with an increased irrigation application amount of 5.04 ML/ha that increased on-farm energy consumption to 9.6 GJ/ha. The associated GHG emission is also increased to 666 kg CO₂/ha.

To further investigate the effects of irrigation, Farm #3 is modified by reducing the irrigation application amount to 3 ML/ha (Farm #5). Total energy use is further reduced to 6.8 GJ/ha, with a GHG emission of 470 kg CO₂/ha. If the irrigation amount is increased to 6 ML/ha (Farm #6), then

total energy will be increased to 10.6 GJ/ha. This is 1.56 times of reduced irrigation at Farm #5 of 6.8 GJ/ha.

In relative terms, the total on-site energy use is increased by 19% (from 8.1 GJ/ha to 9.6 GJ/ha) from supplementary to full irrigation. Carbon emissions are increased by 18% from 566 kg CO₂/ha to 666 kg CO₂/ha. In comparison total on-site energy use is increased by 56% (from 6.8 GJ/ha to 10.6 GJ/ha) when there was a greater difference in water application amounts.

Conventional harvester vs. roundbale harvester

To study the effect of different types of harvesters, a basket (conventional) harvester (Farm #7) was compared with Farm #8 (roundbale harvester). It can be seen that the total on farm energy can be reduced from 18.7 GJ/ha to 18.0 GJ/ha (4%). The associated GHG emission is also reduced by 4% from 1300 CO₂/ha to 1254 kg CO₂/ha.

Other considerations

Previous work reported by Baillie (2009) has also examined the impacts of reduced tillage and zero tillage farming systems at Keytah in the Gwydir Valley. In comparison to the scenarios identified above, reductions in energy use of 12% and 24% were achieved for reduced and zero tillage relative to conventional practices on the site.

It is noted that the above calculations have not accounted for the efficiency of electricity generation which is off farm and is normally about 40%. If this is adopted, it will inflate the total primary energy use of electric water pumping by a factor 2.5. In this case, the total primary energy use at Farm #1 will be increased to a very significant 23.2 GJ/ha, with the corresponding GHG emission of 2074 CO₂/ha. These two numbers are respectively 3.4 and 4.4 times of assumed Farm #5 case scenario. This shows the significant variation and potential effect of different farming system and energy accounting methods on the final calculation results.

It is further noted that the above calculations of the 3 scenarios are not full life cycle analyses as the impact of indirect inputs of chemical and fertilisers have not been taken into account in these models. Because cotton is a high-input crop, on-farm indirect inputs can often have a very significant influence on the energies used in the production of finished cotton lint. In many cases, on-farm direct inputs can account for around up to 70-75% of total energy used in cotton production.

7. Project Outcomes

Energy savings initiatives can often be one of the fastest and simplest methods to reduce operating costs while reducing both energy demand and carbon footprint.

Energy Benchmarking Methodology

The energy benchmarking methodology, presented in Appendix A provides a vehicle to extend energy benchmarking and analysis to the entire cotton growing community. Presently, the method is being extended to the CottonInfo team via an Energy Efficiency Innovation Grant (EEIG) funded project. This document brings together substantial background IP provided by NCEA. This methodology works in conjunction with EnergyCalc and EnergyCalc Lite.

Library of Energy Use for Various Operations

The library of on-farm energy use provides knowledge of energy used in different operations. It is a set of energy use benchmarks for various operations that show average, high and low energy use for each operation.

The importance of this information cannot be underestimated. Simply, the library of energy use provides the necessary information for a novice auditor, with no measured data, to conduct an energy use audit. These values are incorporated into EnergyCalc and EnergyCalc Lite.

EnergyCalc

EnergyCalc is a user-friendly tool that works in conjunction with the energy benchmarking methodology presented in Appendix A. It is a multi-crop software that allows for the user to input their production of not only cotton but wheat, oil seeds and any other crops whatsoever. This has resulted in an energy assessment tool that is directly applicable to cotton and generic to agriculture. This assists with benchmarking between industries. Further details can be found in *Appendix B: EnergyCalc Users' Manual*. and *Appendix C: EnergyCalc Information Sheet*. EnergyCalc can be found online at <http://kmsi.nceaprd.usq.edu.au/>

EnergyCalc is designed to:

- Assess direct on-farm energy use, costs and greenhouse gas emissions associated with diesel, petrol, LPG and electricity consumption.
- Examine energy use within a production system.
- Evaluate farming practices such as tillage, spraying, irrigation etc.
- Each user has their own unique logon and can only see their own information, which is critical for trust and confidentiality of the tool.

EnergyCalc has been substantially upgraded during this project. Changes to EnergyCalc include a modified report, which now includes i) summarised energy inputs ii) actual machinery / energy inputs and iii) performance indices based on production and area. Other functional changes include the ability to export data in an Excel (.csv) format for further analysis and reporting.

EnergyCalc Lite

While not directly an outcome of this project, the lessons, including methodology, assessment process and practices developed for the energy module of myBMP, have informed the development of EnergyCalc Lite.

The energy assessment framework and methodologies developed in NEC1101 have been incorporated into myBMP. As an enhancement, the energy assessment process and supporting methodology has been further extended through separate CRDC funding to develop a mobile version of EnergyCalc known as EnergyCalc Lite.

EnergyCalc Lite has been developed for iPad mobile platforms as an easy to access and easy to use tool, making it more farmer friendly and field accessible for undertaking on-farm energy assessments. EnergyCalc Lite has a list of actions that are consistent with the energy saving practices listed in myBMP and informed through the current work. Functionality has also been developed linking EnergyCalc Lite with myBMP to automatically update a user's profile (i.e. energy saving practices currently adopted) and to synchronise new practices as they are added to the myBMP site via the current work (dependant on changes to the myBMP site).

In effect, a mechanism has been created to now link the project outputs with myBMP and the cotton farmer via the EnergyCalc mobile app. Currently the synchronisation features are inactive due to changes required to the myBMP site; however these features can be easily activated once the myBMP modifications are in place.

The project has been liaising with Janelle Montgomery to pilot the tool amongst farmers, including Hamish Johnstone (PrimeAg, MacIntyre Downs), for feedback.

More recently, the Energy module contained in myBMP has been revised to coincide with the relaunch and upgrade of the myBMP framework and site.

7.1. Opportunities to Reduce Energy Use and GHG emissions

While opportunities for reduction of energy use and GHG emissions are site specific, this section provides a discussion as to the general trends of energy savings. To put the size of different potential energy savings areas into perspective, a summary is provided here that ranks the key opportunities to reduce energy use and GHG emissions. Detail is provided in subsequent sections.

Experience from this project tells us that most growers have good knowledge of where energy (fuel, fertiliser and chemicals) is used in their operation. There are also many instances where the perceived energy use was significantly different to the *measured* energy use. Measurement provides a baseline to evaluate any energy conservation strategies. *Benchmarking* improves profitability for those involved because it identifies where improvements can be made through comparison with others.

Fertiliser and chemical use have the largest impact on the total energy equation. As shown in *Section 6.1. Life Cycle Energy Use*, they account for around 70% of all energy used from planting to the production of ginned cotton lint. While any savings in fertiliser and/or chemical use may be more challenging to obtain, they will have large returns on the total energy budget.

Energy used for irrigation *pumping* is 40 to 70% of all on-farm direct energy use. Pump efficiencies range from 70% down to 40% and less. (That is, a pump that is 70% efficient will use nearly half the energy compared to a 40% efficient pump to shift the same volume of water over the same height.) There is both scope for some significant gains in efficiencies and large returns for these savings.

Tillage efficiency is an important consideration for energy efficiency. Significant gains have been made in the past by reducing the amount of tillage operations, particularly primary tillage.

Because the energy cost of water is high, any savings in *application efficiency* (i.e. wastes less water) will realise energy savings through reduced pumping.

LPG injection for diesel pumping and transport is an option immediately available to the industry with a reasonable return on investment.

The remaining recommendations will, generally, have less significance to the cotton industry and are included as background information.

To assist in the analysis of this complex problem, energy analysis was framed in terms of:

1. Energy Demand, which looks at practice or infrastructure change or refinement.

2. Energy source (fuel switching).
3. Tariffs and costs, which aims to reduce the cost of the existing energy.

7.1.1. Energy Demand

Measurement and Benchmarking

Benchmarking improves profitability for those involved because it identifies where improvements can be made. Benchmarking provides a relative assessment of performance with others under similar circumstances therefore identifying high or low performance at the enterprise level. While benchmarking does take some effort and coordination to initiate, it is not a difficult exercise.

Measuring energy use is relatively easy. The hard question is what to do to reduce energy consumption and/or cost?

An itemised energy assessment is an important piece of the puzzle. It enables an auditor to identify where energy is being used. It enables participation in benchmarking studies which can help identify where energy consumption is higher than normal. Energy measurement identifies the size of each cost area and therefore the relative gains of any improvement.

Investigations identified, consistently across all enterprises, that diesel was the most significant source of direct on-farm energy consumed on farm. Energy and cost savings strategies targeting diesel use are therefore a key consideration and recommendation from this work.

Measuring diesel use is the most important first step which because it measures the majority of your energy use. In these case studies, excluding horticultural processing, diesel supplied 95% of cotton producer's agricultural energy need.

The following steps will provide a robust measurement of itemised diesel use.

- At the start of each season take a reading of the volume in each storage tank.
- Keep all of your fuel delivery dockets or other statement showing fuel delivered.
- Using a meter on each fuel trailer to provide an accurate measurement of your energy use.
- Record the following things:
 - a. Date.
 - b. Litres pumped.
 - c. Machine (e.g. 'old Toyota' or 'JD9440').
 - d. Engine hours or kilometres at the time of the fill.
 - e. Operation. (You should have already defined what categories you will use and what fits into them as part of your benchmarking process.)
 - f. Crop

There are many suppliers of fuel meters. One example, suitable for an overhead tank, is the McNaught 1-inch fuel meter for 10 to 100 L/min, model F025-1S3 with mechanical rolling numbers and reset button retails for \$1044.20 + GST.

Processing the logbook data into useable information is not difficult. Once data has been entered from a fuel logbook it is a reasonably straightforward process to produce a report showing how

much diesel is used for each activity. It is possible to have an accounting firm, a secretariat or similar organisation to provide these analyses.

Benchmarking energy use does improve profitability for those involved because it identifies where improvements can be made. Benchmarking provides a relative assessment of performance with others under similar circumstances therefore identifying high or low performance at the enterprise level. While benchmarking does take some effort and coordination to initiate, it is not a difficult exercise. Accounting firms are the obvious location for benchmarking – financial and energy – to occur.

Alternatively, a farmer may choose to simply use EnergyCalc or EnergyCalc Lite. These tools use standard values so are less accurate for an individual situations. However they offer convenience and ease of use.

On-farm Indirect Energy Use

Because the on-farm indirect inputs of fertilisers and chemicals dominate the total life cycle energy input and greenhouse gas emissions, it is thus particularly important to promote the uses of precision-agriculture techniques such as precision spray systems and precision fertiliser applications. This will not only save the cost of having to purchase these expensive resources, but also have the benefits of reducing the related environmental impacts.

Water Pumping

Water pumping is the largest direct on-farm energy cost for a grower. Pump efficiencies will typically vary between 40 and 70%. That is, a pump that is 70% efficient will use nearly half the energy compared to a 40% efficient pump to shift the same volume of water over the same height.

Informal investigations suggest that pump efficiencies are an area where gains might be possible. Factors that suggest this are: many pumps have been changed ad hoc over the years and many were never design properly in the first instance. Additionally many pumping installations are aging and have high levels of wear.

Pumps are a 'forgotten' part of the energy equation. Farmers will usually aim to have the latest tractors with on-board engine management and traction management systems that get the best out of every litre of diesel. Many have systems that communicate with the grower in real time. Conversely, typically pumps have little in the way of engine or pump management systems; they are often largely forgotten. Tail water return pumps are particularly prone to these factors. However, pumping is 40 to 70% of the total direct on-farm energy bill.

A Level three investigation by this project of one of pumping station shows very significant savings are possible.

Water Application Efficiency

Water use efficiency is undoubtedly increased with more sophisticated systems such as lateral move and drip irrigators. Work by Kahatri and Smith (2011) suggests that intelligent optimisation of surface irrigation can make significant improvements to the irrigation application efficiency (i.e. reduced water losses) as well as reduce the energy used in applying the irrigation water.

	Application efficiency	Water applied ML/Ha	Water Savings ML/Ha	On-farm Energy use (GJ/ha)	Change in energy use (GJ/ha)
Current surface irrigation	55%	7.3		12.8	0
Real-time optimised surface irrigation	85%	4.7	2.6	11.7	-1.1
Centre-pivot irrigation	90%	4.4	2.9	17	4.2
Drip irrigation	95%	4.2	3.1	16	3.2

Figure 26: Irrigation application efficiency and energy costs, modified from Kahatri and Smith (2011)

Tillage Efficiency

Tillage efficiency is an important consideration for energy efficiency. Significant gains have been made in the past by reducing the amount of tillage operations, particularly primary tillage. In-cab fuel use displays may assist in this process by providing feedback to the operator to make adjustments such as working depth. Energy use measurement and benchmarking provides information that may be useful to evaluating the type and number of tillage operations.

Tractive Efficiency

Most tractors employed for cotton production are modern machines that are equipped with integrated engine and traction management systems. There appears to be less potential for increased efficiency in the tractor itself. However, general information regarding tractor fuel efficiency can be found at: <http://uk.efficient20.eu/> and at <http://uk.efficient20.eu/guide.pdf>. This site quotes the following factors and their corresponding reductions in fuel use

- Soil Structure: 20 – 25%
- Adaptive Driving: 10-20%
- Correct tyre pressures: 5 -15%
- Ballasting: 5 – 8%
- Maintenance: 5 -10%
- Optimising engine performance: 10 – 20% (Engine Full Load Curves; IVT / Powershift; Load sensing hydraulics; eco PTO)
- Implement setup: 20 – 30%
- Diesel Quality: 3 – 5%

7.1.2. Energy Source

LPG Injection on Pumping

Technologies that inject LPG into the diesel stream are now commonplace for both small and large scale, fixed and mobile plant. There are various suppliers in Australia that are experienced in installing and commissioning LPG gas injection systems on large irrigation pump motors. Installation cost typically range from \$3,000 to \$8,000 (depending on location and complexity). Generally gas companies will put onsite an appropriately sized tank at no cost. Alternatively, exchangeable forklift bottles can be used.

Diesel engines typically burn 75% of the fuel in the combustion chamber before the exhaust valve opens. Replacing diesel with up to 35% LPG improves this burn efficiency to typically 95% through

the higher combustion of LPG. Because LPG has a lower energy density, the 35% of LPG injected reduces diesel consumption by 30%. Other advantages of the cleaner burn are extended oil change intervals of up to 10%, a reduction on CO2 emissions and up to 50% reductions in NOx emissions. Exhaust temperature drops by around 5% due to more efficient combustion.

An LPG injection system installed by Diesel Gas Technologies (<http://dieselgas.com.au/>) and monitored during the project produced significant savings over one season. In addition to the \$3,683 saved, the system will, through a more efficient burn of diesel, reduce total energy use by 1,197 MJ and GHG emissions by 105 kg CO2-e.

DieselGas Technologies Consumption Calculator					
Enter required data in the WHITE boxes only					
Owner/Operator					
Unit Description	Volvo Penta				
Litres per Hour	30.4 l		Select Diesel Rebate		0 c
Annual Hours	1000 hrs		Select LPG Rebate		0 c
Diesel Cost	112 c/l	Ex GST 101.82	Actual Diesel Cost		101.82 c
LPG Price	68 c/l	Ex GST 61.82	Actual LPG Cost		61.82 c
Service Life	6 yrs				
Consumption Comparison					
	Diesel	Gas			
Diesel Only	30.4 l/h	Nil	Diesel Reduction %		29.5%
DieselGas	21.43 l/h	8.816	Gas Substitution %		29.0%
Cost Comparison					
			Per Hour		Per Annum 1000 hrs
Diesel Only	30.4 l/h	diesel is	\$30.95 /hr and		\$30,952.73 per annum
Diesel	21.43 l/h	diesel is	\$21.82		
LPG (Propane)	8.816 l/h	LPG is	\$5.45		
			\$27.27 /hr and		\$27,271.56 per annum
			Saving per hour		\$3.68
			Estimated annual savings		\$3,681.16
			Savings over remaining service life		\$22,086.98

Figure 27: Dollar savings derived from LPG gas injection

LPG injection for Transport

eCo-Shot, at URL http://www.ecoshot.com.au/trucks/images/kenk104_fuel.jpg provide measured savings for a C15 Caterpillar truck engine used to haul a b-double. For diesel-only consumption, a figure of 1.9 kilometres per litre is quoted. For diesel and LPG combined, figures of 2.6 and 32.78 kilometres per litre respectively are quoted. Assuming that a truck completes 20,000 kilometres per season at 1.4 kilometres per litre of diesel, scaling the eCo-Shot consumption figures by 1.4/1.9 to match the assumed fuel consumption, fuel use with LPG injection would equate to 1.9 km/L for diesel plus 24.2 km/L for LPG. Assuming a diesel cost of \$1.41 per litre before rebate and an LPG cost of \$0.723 per litre before rebate, with no rebate claimable for on-road use annual saving would be in the region of \$4,800. Installation costs are \$3,000 to \$8,000 depending on location and complexity. An installation cost of \$6,000 would give a healthy return on investment of 80%. If the 20,000 kilometres was completed in thirty days, daily LPG use would be around 20 litres per day. Payback period would occur within 25,000kms.

Diesel Verses Electric?

The following figure looks at the cost of diesel and electricity and how well these are converted to output mechanical energy by their respective motors. Cost assumptions of diesel, ULP and electricity are made and are stated in the figure below. Energy conversions factors are repeated from Figure 4. The efficiency of converting this energy into useable mechanical power varies with the type of motor. Diesel motors output 35% to 45% of the power they consume from the input fuel and electric motors convert 75% to 95% of the power they consume. From these assumptions the cost of useable, output mechanical power is derived in the final column of figure 28, below.

	Unit	\$/unit	MJ/unit	Energy cost cents/MJ	Engine efficiency	cents /output MJ
Old diesel motor	L	1.41	38.6	3.65	35%	10.4
Modern diesel	L	1.41	38.6	3.65	45%	8.1
Old ULP motor	L	1.33	34.9	3.81	28%	13.6
Modern ULP	L	1.33	34.9	3.81	36%	10.6
Electric motor	kWh	0.24	3.6	6.76	85%	9.0
Electric motor	kWh	0.24	3.6	6.76	95%	7.1

Figure 28: Comparison of energy sources

Changing from diesel to electric pumping is capital intensive with \$100,000 to \$300,000 being a possible upgrade cost range. Additionally, pump locations must be close to existing power grids else the cost of installing power lines, in the order of millions of dollars, is prohibitive.

Electrical tariffs must be closely examined. Be especially careful with any tariff that includes a 'peak demand' charge. Likely future rises in the cost of wholesale and retail electricity must also be considered.

Biofuels

Commercially available biofuels are currently around 4% more expensive than diesel. As the cost of diesel increases, and as biofuel production technology advances, biofuels will become more competitive with diesel. Biofuels are renewable fuels that can reduce CO₂-e emissions by up to 15 to 20% or more, compared to traditional fossil fuels. The extensive and distributed nature of cotton production necessitates tractor and truck transport. Thus, biofuel has the potential to assume an important portfolio in future energy for agriculture as the cost of diesel continues to rise. The most widely utilised biofuels in Australia are ethanol blended petrol and diesel. Production of biodiesel from cottons seed is less economic than other seeds due to slightly lower oil content. It is recommended that biofuels be monitored as a possible option into the future.

7.1.3. Tariffs and costs

Bulk Purchasing

Bulk purchase of diesel, fertiliser and chemicals is a general recommendation that will require further research. Companies who purchase very large quantities of diesel or other commodities have been able to purchase the diesel in bulk to realise cost savings. That is, the diesel is purchased

from the port terminal, and trucked directly to the growers involved. A grower cooperative of three or more farms would be an ideal structure for such a venture. Grower cooperatives are common in other agricultural industries, such as sugar cane harvesting for example.

Bulk purchasing of electricity requires greater than 50MW hours purchased per annum. The customer is then contestable supply, and various brokers are available to provide this energy.

8. Conclusions

While farmers at each site were found to have a good awareness of energy use there were examples where farmers were surprised by measured values. Most farmers had good records or at least access to good data.

Estimation techniques are an acceptable method of performing an energy analysis. The library of energy use benchmarks provides a foundation to perform energy audits. These benchmarks enable an auditor to perform a reasonable energy use analysis with little data requirements. The provision of an energy benchmarking methodology enables industry participants, such as the CottonInfo team, to extend energy use benchmarks across the cotton production industry. EnergyCalc is an on-line electronic resource which encapsulates expert knowledge and allows a novice user to perform energy assessments. Importantly, EnergyCalc is now loaded with well-measured default values and serves as an energy use estimation tool for most analyses. EnergyCalc Lite uses the same default values and calculation techniques. It provides similar functionality on the iPad platform and is the preferred myBMP delivery method.

Energy consumed in water pumping may offer significant potential for energy savings in the cotton industry. Water pumping is the largest direct on-farm energy cost for a grower. Pump efficiencies will typically vary between 40 and 70%. That is, a pump that is 70% efficient will use nearly half the energy compared to a 40% efficient pump to shift the same volume of water over the same height. Many pumps have been changed ad hoc over the years and many were never design properly in the first instance. Additionally many pumping installations are aging and have high levels of wear. Pumps are a 'forgotten' part of the energy equation.

Fertilisers and chemicals are a hidden (indirect) energy cost that accounts for 70% of the energy used in production of finished lint. Increased yields through improved varieties and agronomy demand increasing rates of fertiliser. While BT varieties have seen significant reductions in pesticides, minimum till systems with glyphosate tolerant varieties have increased herbicide use. The actual balance between energy saved in reduced tillage and increased herbicide use is unknown and is worthy of further research. While any savings in fertiliser and/or chemical use may be more challenging to obtain, they will have large returns on the total energy budget.

There is less variation in in-field operations than was previously thought. The majority of tractors used for cotton production have at least some level of engine and traction optimisation system, there is less likely to be significant energy savings in the tractor itself.

Tillage efficiency is an important consideration for energy efficiency. Significant gains have been made in the past by reducing the amount of tillage operations, particularly primary tillage. In-cab displays of real-time fuel use allow the operator to make 'on-the-go' adjustments, such as tillage

depth. Energy use measurement and benchmarking provides information for broader management decisions, such as the number and type of operations.

GPS-based tractor monitoring underestimates total fuel use because fuel used in turning, travelling and other activities is not accounted for. The amount of underestimation varies from around 5% of fuel for high field efficiency operations such as cultivation to 25% of fuel in low field efficiency operations such as spraying. GPS-based tractor monitoring also do not account for ancillary fuel use such as module building, bale handling or transport. GPS-based tractor monitoring systems do provide information useful to an energy audit within these limitations. These systems provide detailed level three information on performance within the field and are useful management tools. However, the latest on-line telemetry systems offered by the major tractor manufacturers seem to have the potential to benchmark in-field energy use.

Because the energy cost of water is high, any savings in application efficiency (ie wastes less water) will realise energy savings through reduced pumping.

LPG injection for diesel pumping and transport is an option immediately available to the industry with a reasonable return on investment.

9. Extension Opportunities

The results of this project are currently being delivered to the cotton industry via the CottonInfo team with EEIG funding. Primary areas of extension are:

- Awareness of the importance of energy use.
- Energy measurement and benchmarking.
- The detailed benchmarks of energy use derived from the project.
- The importance of pump evaluations.
- The usefulness of electronic monitoring systems.
- Other energy saving strategies mentioned in this project

This extension is supported by:

- The document 'A standardised practical methodology for benchmarking on-farm energy use and greenhouse gas emissions on cotton farms.' which is attached in Appendix A.
- The EnergyCalc software, which is available at <http://kmsi.nceaprd.usq.edu.au/>. Note that a username and password is required to access this software.
- Background IP provided by the NCEA. EnergyCalc Lite and various other resources.

Areas for further research include:

- Benchmarking of pump performance.
- The usefulness of the latest web-based tractor telemetry systems in energy benchmarking.
- Continued improvement of benchmark values of individual operations.
- The net energy balance between decreased tillage and increased herbicide use in glyphosate resistant varieties.
- Opportunities to reduce herbicide and pesticide use through precision application systems.
- Detailed quantification of on-farm indirect energy use.

- Opportunities to improve irrigation application efficiencies through intelligent application systems.

Extensive publications and communications have been generated from this project. Please refer to *Appendix G: Promoting Energy Assessment and Reporting Tools* for full details.

References

ANSI/ASABE S612 JUL2009 Performing On-Farm Energy Audits. (2009) American Society of Agricultural and Biological Engineers. 2950 Niles Road, St. Joseph, MI 49085-9659, USA ph. 269-429-0300, fax 269-429-3852, hq@asabe.org

AS/NZS 3598:2000, Energy Audits, Jointly published by Standards Australia International Ltd, GPO Box 5420, Sydney, NSW 2001 and Standards New Zealand, Private Bag 2439, Wellington 6020, ISBN 0 7337 3576 2

Baillie, C. (2009), Energy and Carbon Accounting Case Study (Keytah), National Centre for Engineering in Agriculture Publication 1003254/1, USQ, Toowoomba.

Baillie, C. P., Pyke, B (2010) Managing direct energy use now and in the future. In: 15th Australian Cotton Conference: Fashioning the Future, 10-12 August 2010, Broadbeach, Qld, Australia

Chen, G. and Baillie, C. (2007), Development of EnergyCalc - A Tool to Assess Cotton On-Farm Energy Uses, National Centre for Engineering in Agriculture Publication 1002565/1, USQ, Toowoomba.

Chen, G., Baillie, C, Eady, S., Grant, T. (2013), "Developing Life Cycle Inventory for Life Cycle Assessment of Australian Cotton", Australian Life Cycle Assessment Conference, 14-18 July 2013, Sydney.

Cotton Australia (2013) Cotton Annual 2013 – A collection of statistics across 20 key area of Australian cotton production. Cotton Australian booklet.

Department of Climate Change and Energy Efficiency. (2012) National Greenhouse and Energy Reporting System Measurement: Technical guidelines for the estimation of greenhouse gas emissions by facilities in Australia. <http://www.climatechange.gov.au> ISBN: 978-1-922003-52-2 (print); 978-1-922003-51-5 (online) © Commonwealth of Australia 2012

Eady S., (2012) Pers. Comm. Developing a LCI database for Australian agriculture, a Rural Industries Research and Development Corporation funded project. Commonwealth Scientific Research Organisation.

Fairport Farm Software (2011), PAM QA Plus r7.1.6, software, <http://www.fairport.com.au/en/>

Smith, R. J. and Baillie, J. N. and McCarthy, A. C. and Raine, S. R. and Baillie, C. P. (2010) Review of precision irrigation technologies and their application. Project Report. National Centre for Engineering in Agriculture, Toowoomba, Australia.

Khabbaz, B.G. (2010) Life cycle energy use and greenhouse gas emissions of Australian cotton: impact of farming systems. Master of Engineering Dissertation, University of Southern Queensland, Australia.

McHugh, A.D., Clarke, J. Erol, C. and Eberhard, J., Development of a framework and tools for packing shed water and energy audits, National Centre for Engineering in Agriculture Publication, University of Southern Queensland, Toowoomba

McHugh, A.D., Erol, C. and Eberhard, J. (2010). SEQ Irrigation Futures R&D Support: Horticulture. Development of a framework and tools for packing shed water and energy audits. National Centre for Engineering in Agriculture Publication 1003530/16, USQ, Toowoomba.

Roth G 2010, Economic, Environmental and Social Sustainability Indicators of The Australian Cotton Industry, Cotton Catchment Communities CRC / University of New England, www.cottoncrc.org.au

Saunders C., Barber A., Taylor G., (2006) Food miles - comparative energy / emissions performance of New Zealand's agriculture industry. Lincoln University (Canterbury, N.Z.). Agribusiness and Economics Research Unit) ; Monograph no. 285. ISBN: 0-909042-71-3

Sharing Irrigation Knowledge for Better Outcomes 28 – 30 May 2013, Conference:

Szabo P. M., J. Montgomery J., Sandell G. R., (2013), development of a pump efficiency monitor for use in cotton irrigation. Irrigation Australia's 2013 Regional Conference.

Appendix A: A standardised practical methodology for benchmarking on-farm energy use and greenhouse gas emissions on cotton farms.



NCEA

NATIONAL CENTRE FOR ENGINEERING IN AGRICULTURE

A standardised practical methodology for benchmarking on-farm energy use and greenhouse gas emissions on cotton farms.

Sandell G.R., Baillie C.P., Chen G.

**National Centre for Engineering in Agriculture
University of Southern Queensland
Toowoomba**

**NCEA Publication 1004068/2
September 2013**



UNIVERSITY
OF SOUTHERN
QUEENSLAND



NCEA

National Centre for
Engineering in Agriculture



Australian Government
**Cotton Research and
Development Corporation**



NCEA
National Centre for
Engineering in Agriculture

Disclaimer

While the National Centre for Engineering in Agriculture and the authors have prepared this document in good faith, consulting widely, exercising all due care and attention, no representation or warranty, express or implied, is made as to the accuracy, completeness or fitness of the document in respect of any user's circumstances. Suppliers, companies and their products mentioned in this document do not infer endorsement by the NCEA. Users of the report should undertake their own quality controls, standards, safety procedures and seek appropriate expert advice where necessary in relation to their particular situation or equipment. Any representation, statement, opinion or advice, expressed or implied in this publication is made in good faith and on the basis that the National Centre for Engineering in Agriculture, its agents and employees, and the Cotton Research and Development Corporation, CRDC (the commissioning Agency) are not liable (whether by reason of negligence, lack of care or otherwise) to any person for any damage or loss whatsoever which has occurred or may occur in relation to that person taking or not taking (as the case may be) action in respect of any representation, statement or advice referred to above.

Acknowledgements

This work was fully funded by the Cotton Research and Development Corporation. Extensive background IP was provided by the National Centre for Engineering in Agriculture.

Copyright

Published in September 2013 by the National Centre for Engineering in Agriculture, Toowoomba. Material from this publication may not be used unless prior written approval has been obtained from the National Centre for Engineering in Agriculture and the Cotton Research and Development Corporation.

This document should be cited as follows:

Sandell G.R., Baillie C.P., Chen G., (2013). Practical guidelines for benchmarking on-farm energy use and greenhouse gas emissions on cotton farms. Cotton Research and Development Corporation report. National Centre for Engineering in Agriculture, Publication 1004068/2, USQ, Toowoomba.

Contents

Introduction	1
Scope.....	2
On and Off-Farm, Direct and Indirect Energy Use	2
Cotton Life Cycle Energy Use	4
On-farm indirect energy use.....	4
Off-farm direct and indirect energy use (ginning).	4
On-farm direct energy use.....	5
Definitions.....	6
Measurement accuracy	8
Audit Types	8
Level One Energy Audit Description	8
Level Two Energy Audit Description	8
Level Three Energy Audit Description.....	9
Audit Methodology	9
Fertiliser and chemicals	9
Conversion Factors.....	10
Level One Methodology.....	10
Level one error rates.....	11
Mixed farming operations	14
Level Two Methodology.....	14
Equipment List	15
Contractors	15
Measurement of Diesel use	15
GPS systems and the measurement of diesel use.	16
Synthesis of diesel use where no records existed	16
Measuring electrical energy.....	18
Workshop and domestic electricity supply.....	18
Pumping electricity	18
Measurement of ULP, LPG and other fuels	19
Level Three Analysis	20
Recommendations	20
Reporting	21

Introduction

Energy efficiency is becoming increasingly important globally in the context of rising energy costs and concerns over greenhouse gas (GHG) emissions and global warming. Energy efficiency is particularly important for agriculture because it relies heavily on not only direct inputs such as diesel but also on energy intensive inputs. Energy efficiency is particularly important for Australian cotton production, which relies heavily not only on energy directly consumed for water pumping, tractors and harvesters and transport but also on energy consumed indirectly in chemicals and fertilisers.

An energy audit is an assessment of energy needs and efficiency through a systematic examination of an entity, such as a firm, organisation, facility or site, to determine whether, and to what extent, it has used energy efficiently. They identify energy saving opportunities that do not adversely affect the output(s) and may highlight potential improvements in productivity and quality. They may also assess any potential energy cost savings, for example, through fuel switching, tariff negotiation and demand side management.

Energy audits may be one of the fastest and cheapest ways to control production costs and improve environmental responsibility of cotton production. Being able to measure energy use will result in better understanding of the use of energy and thus where energy saving strategies can be best targeted. As Australia's cotton production is almost entirely exported, any improvements in energy efficiency will improve Australia's 'clean and green' image.

The process of improving on-farm energy use may start with an energy audit which benchmarks and establishes energy saving opportunities. The Plan-Do-Review-Improve (PDRI) approach (Figure 1) is commonly used in continuous improvement initiatives and often adopted for energy management.



Figure 1: Plan Do Review Improve cycle

Scope

This methodology is designed for Australian cotton producers to:

- a) assist energy users to decide what level of audit is appropriate for their needs;
- b) provide a guide for energy users when commissioning energy audits;
- c) provide a uniform basis for preparing and comparing energy audit proposals;
- d) support the establishment of an energy management program by specifying pre- and post-audit activities for the energy user organisation;
- e) define suitable reporting requirements for the audit; and
- f) contribute to the quality of existing energy and other management systems, e.g. financial, environmental, operational or occupational health and safety management.

This methodology is designed to quantify direct, on-farm energy use, as defined below. This methodology, while written in terms of direct, on-farm energy use can equally be extended to quantify energy used in fertilisers and chemicals. Please refer to *Audit Methodology – Fertilisers and Chemicals* for further discussion.

This methodology is adapted from the Australian/New Zealand Standard ASNZ 3598:2000 Energy Audits. While standard is recommended further reading it is designed for the building industry there are some key differences between ASNZ 3598:200 and this methodology.

On and Off-Farm, Direct and Indirect Energy Use

Direct energy relates to the energy used for undertaking a particular farming task while indirect energy represents the energy embodied in the manufacture of farming inputs. On-farm and off-farm inputs provide a demarcation of where this energy use occurs. For example:

- On-farm direct inputs (e.g. fuel uses due to tillage and other field work)
- On-farm indirect inputs (e.g. manufacturing of fertilisers and on-farm machinery)
- Off-farm direct inputs (e.g. ginning and road transportation)
- Off-farm indirect inputs (e.g. manufacturing of processing machinery and storage facilities)

An energy audit would typically investigate direct on-farm energy use (such as the consumption of diesel, ULP, electricity and other similar sources) and this guide is written in these terms. It is important to note that the same process could be easily extended to fertiliser, chemicals and other on-farm indirect energy use. This is discussed in *Audit Methodology – Fertilisers and Chemicals*.

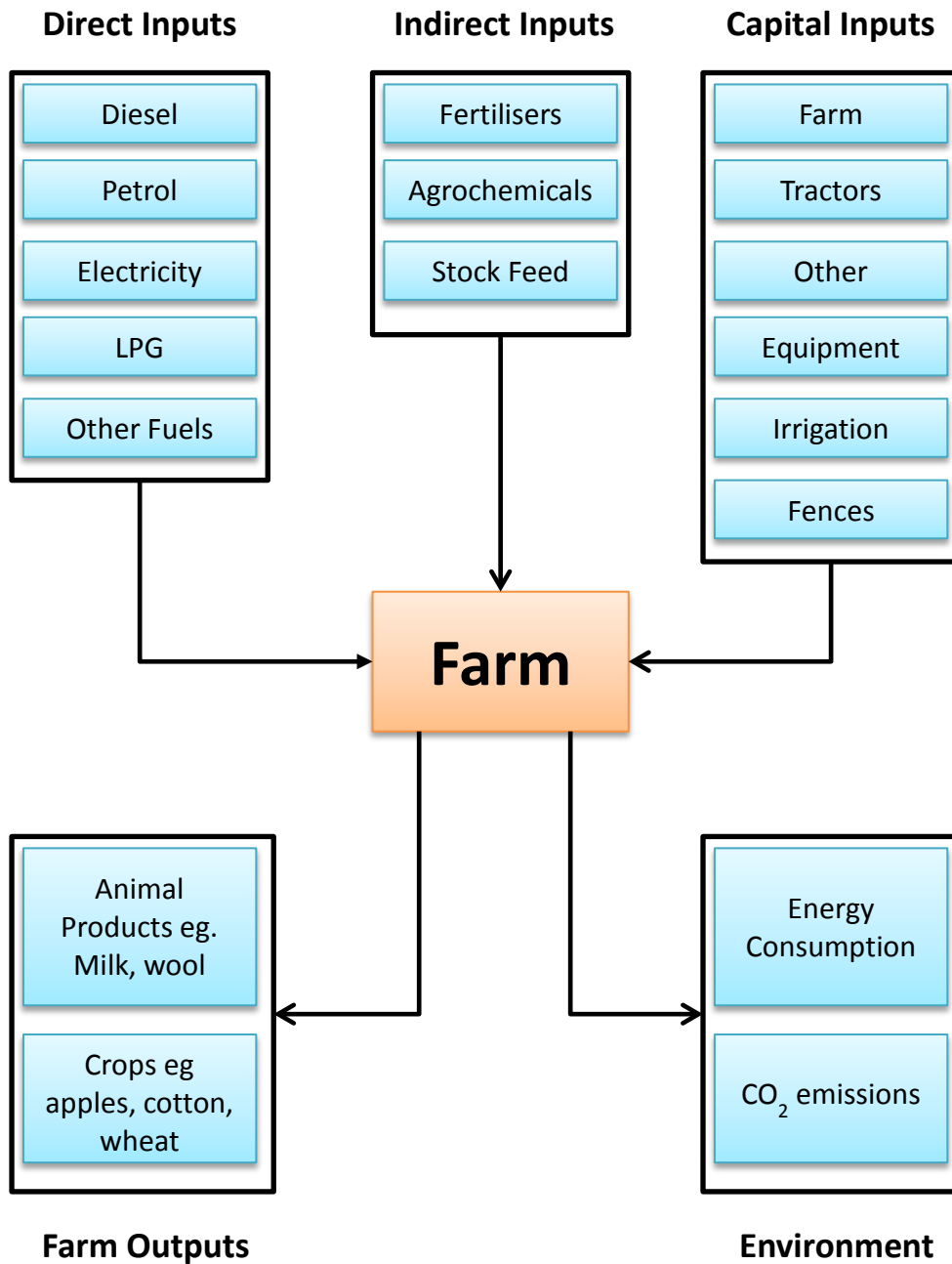

Figure 2: Various inputs of farm production (Saunders, Barber, Taylor, 2006)

Cotton Life Cycle Energy Use

Cotton production, that is production of ginned cotton ready for transport to textile mills, requires a lot more total energy than is used directly on-farm. Figure 3, below, shows the results of a study that measured energy use from initial production through to finished product.

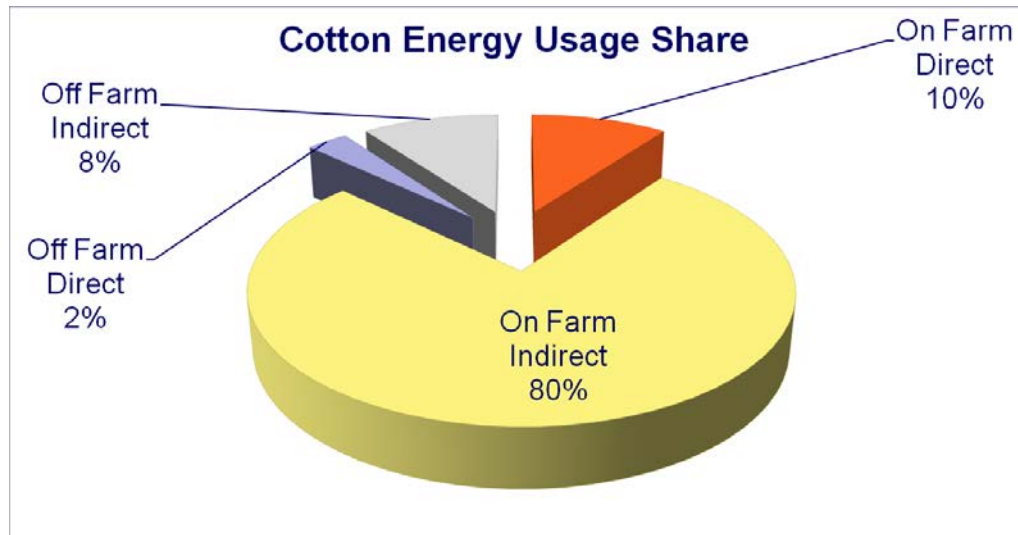

Figure 3: Life cycle energy use for the production of ginned cotton lint.

On-farm indirect energy use

On-farm indirect energy use is the largest component of energy use. On-farm indirect energy use is largely the fertilisers and chemicals that are used in cotton production with a smaller amount of energy used in machinery production. Therefore, as discussed in the section *Audit Methodology – fertilisers and chemicals* it is prudent to perform the same exercise in fertiliser and chemical use.

Off-farm direct and indirect energy use (ginning).

Off-farm indirect energy is used in the manufacturing of processing machinery and storage facilities.

Off-farm direct energy use is the energy consumed in cotton ginning. The same study showed that total energy use for cotton ginning was 212 to 324 MJ per bale which included 61% from electricity and 39% from LPG used in drying cotton. Total CO₂-e emissions were in the order of 68 kg CO₂-e per bale and energy costs were \$6 to \$13 per bale.

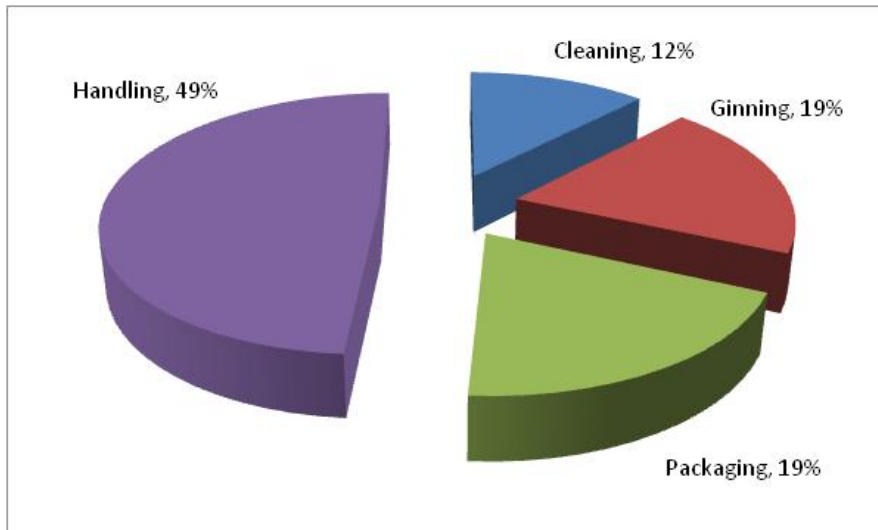

Figure 4: Direct energy use in cotton ginning.

On-farm direct energy use

On-farm direct energy use accounts for around 10% of total energy used in the production of ginned cotton lint. Although only 10% of the total energy footprint the cost is a significant proportion of the total farming input costs (i.e. why growers are sensitive to fuel and electricity prices). Importantly, on-farm direct energy use is an area where savings may be possible and any savings in these areas flow directly to the farmer and help the overall efficiency and profitability of the cotton industry.

Figure 5, below, shows a typical breakup of direct on-farm energy use for a river irrigator.

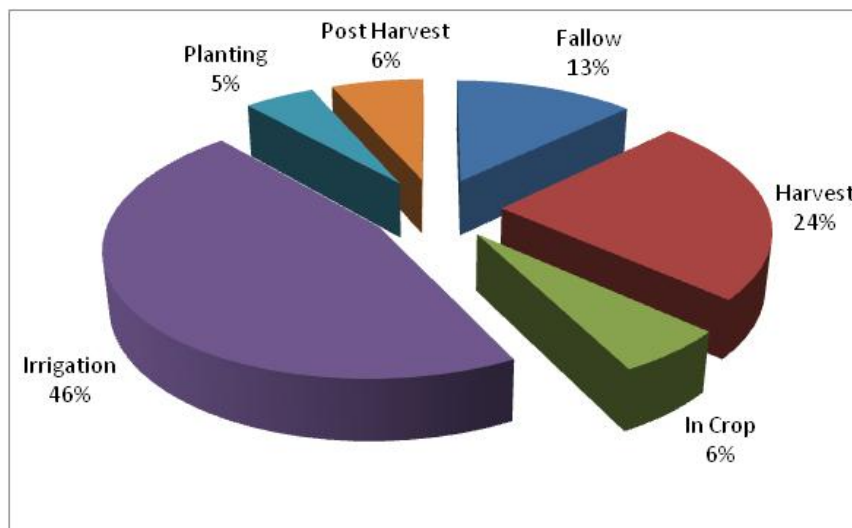

Figure 5: Typical direct on-farm energy use for a river irrigator

Irrigation is the largest component of direct on-farm energy use. Irrigation energy use is typically 40 to 60% of total energy for river irrigators and up to 70% of total energy for bore water irrigators.

Definitions

The terms used to describe different levels of energy audits in this report have the following specific meanings:

Benchmarking

The use of energy performance indicators to compare the energy use of the site under review with similar sized sites performing the same function and, thus, establishing whether energy consumption is high, reasonable or clearly efficient.

CO₂-e

Carbon dioxide equivalent: Different gasses have higher and lower contributions to the greenhouse effect. Methane, for example, has thirty times the impact of carbon-dioxide (CO₂). Carbon dioxide equivalency is a quantity that describes, for a given mixture and amount of greenhouse gas, the amount of CO₂ that would have the same global warming potential

Energy

The fuel, electricity and heat consumed within the site. Energy sources can be non-renewable and renewable, e.g. wind, solar, biomass.

Energy intensity

The energy use per unit of activity. For example it could be the MJ of energy per hectare of production or kg CO₂-e per bale of cotton. Energy use, GHG emission and costs are each normally expressed per unit of production (one bale, one tonne), per hectare.

Energy management

All activities of the organisation's overall management functions which contribute to the achievement of objectives and targets of the Energy Policy. NOTE: There may be no formal energy policy in place. The energy policy might be no more than a simple undertaking to minimise the cost of energy. Nonetheless, there is always some level of energy management, even if it is just switching off (most) lights at the end of the day.

Energy management program

A program to achieve and sustain efficient and effective use of energy including policies, practices, planning activities, responsibilities and resources that affect the organisation's performance for achieving the objectives and targets of the Energy Policy.

Energy monitoring

The regular recording and review of energy consumption and cost.

Energy performance indicator

The application of energy intensity measures in a way that enables comparison between different buildings, processes, geographical locations and performance trends over time.

Energy policy

A concise statement by the organisation of its intentions and principles in relation to its overall energy performance, which provides a framework for action and assists in the setting of its environmental objectives and targets. NOTE: The energy policy should be integrated with the organisation's broader policies.

Energy user

The person or organisation responsible for the energy used on the site and for commissioning an energy audit.

GHG

Greenhouse gas(es). Any gas that contributes to the greenhouse effect by absorbing infrared radiation, e.g. carbon dioxide, methane.

Gigajoule (GJ).

A unit of measurement of energy. A gigajoule is equal to one billion joules, which is equivalent to one thousand megajoules.

Greenhouse coefficient or conversion factor

The arithmetic conversion factor which converts the amount of energy consumed to a measure of greenhouse warming, expressed as CO₂ equivalents CO₂-e. NOTE: These can vary from time to time and should be confirmed with Department of Climate Change and Energy Efficiency.

kW.h

The kilowatt hour, or kilowatt-hour, (kW.hrs, kW·h, kW h or kWh) is a unit of energy equal to 1000 watt hours or 3.6 megajoules. The kilowatt hour is most commonly known as a billing unit for energy delivered to consumers by electric utilities.

LPG

Liquefied Petroleum Gas (LPG) is usually derived from fossil fuel sources, being manufactured during the refining of crude oil, or extracted from oil or gas streams as they emerge from the ground.

Megajoule (MJ).

A unit of measurement of energy. A megajoule is equal to one million joules.

Site

The site is normally defined as the whole farm; however it may be a part of the farm, such as a processing facility within the farm.

ULP

Unleaded petrol

Measurement accuracy

Accuracy is how close your measurement is to the actual value. How accurately you are measuring anything is a critical consideration. If we want to measure a variation or difference of 5% then a measurement system of $\pm 10\%$ is not going to be adequate.

How close your answer is to the true value, or the accuracy of your measurements, will vary greatly. Some estimation techniques provide no way to estimate the accuracy of the result and are regarded as 'best-guess'. Where we measure physical quantities, diesel use for example, there are techniques to estimate how accurate our measurement might be and these are discussed in detail below. The important consideration is that we must be aware of how accurately our measurements are.

Audit Types

Energy audits may be conducted with different levels of detail and these are discussed below. A user may decide to conduct any single level of audit or may conduct a level one audit and then progress to a level two audit and possibly to a level three audit. Each level of audit has its own time and monetary cost.

The level of audit will depend on factors such as

- The potential energy or energy cost saving strategies;
- The level of detail and accuracy required to evaluate proposed changes;
- The total annual energy cost and
- Size of the site.

Level One Energy Audit Description

Overview Audit

A level one audit, sometimes called an overview, is simply the total energy consumption expressed per hectare and per unit of production. This is the simplest and cheapest form of energy audit. A level one audit is a desktop study that involves collating all receipts for diesel, electricity and all other energy sources and similarly for total production and area to derive total energy use per hectare and per unit of production.

Level Two Energy Audit Description

Itemised Audit

Level two energy audits involve breaking down the total energy usage on the farm into energy used in each farming operation. Ideally a level two audit will measure energy used in each operation over a considerable time period, such as a year. Fuel bowsers which specify date, machine, and litres are an excellent resource to conduct a level two analysis. Other sources include electricity invoices for individual meters or the installation of sub-meters if electrical energy use is significant.

Where this information is not available, estimation techniques may be used. This process usually involves considerable farmer interviews and is supplemented by any available fuel and electricity measurements.

Software calculators and tools are often employed in this step because detailed records do not always exist. Manual estimation techniques are relatively more difficult, time consuming and require expert knowledge. Tools such as EnergyCalc provide benchmark figures and in-built expert knowledge. Estimation techniques are less desirable than measured data.

Level Three Energy Audit Description

Specific Operation Audit

Level three energy audits involve breaking down the energy usage during or within a specific operation. Typically, level three audits focus where the greatest energy consumption or greatest potential gains have been identified from a level two audit. This will usually involve a range of different sensors to measure the performance of the machine. Examples of sensors may include pressure (irrigation head), engine RPM, tractor travel speed, torque, load and temperature. A data logger may be required to record the data for a considerable period of time. A level 3 energy audit may be necessary to certify a product/farming operation and to establish the energy-star rating and labelling scheme.

Audit Methodology

The Energy assessment processes goes through a number of phases regardless of what level of assessment is applied. The first phase is data gathering and this step takes some planning and logical thought as it is always slightly different in each situation. Some guidelines and recommendations are presented below. Following the data gathering step, the data is processed to calculate the required ratios (such as MJ/Ha) and charts to be presented in the report. These steps are followed by the development of recommendations, reporting, and a review by the enterprise before the implementation of specific strategies and technologies.

Clearly, the integrity of this process is highly dependent on successful data gathering in the initial phase of the evaluation. The key to a successful energy audit is identifying prior to the season how energy use will be measured and recorded. It is important that likely error rates associated with any measurement methodology be considered and estimated.

Fertiliser and chemicals

A move towards minimum and no till systems in modern agriculture have increased a reliance on agrochemicals and synthetic fertilisers. Transgenic cotton has seen large reductions in the use of many cotton chemicals. It is certainly true to say that synthetic fertilisers and chemicals are an integral part of modern farming.

The production of fertilisers and chemicals are energy intensive. Economics dictate that as the cost of energy rises, so too will the cost of fertilisers and chemicals. For example, one kilogram of nitrogen requires around 100 MJ to produce, which is equivalent to 2.6 litres of diesel, and emits around 1.3 kg CO₂-e into the atmosphere. For herbicides, one kilogram of active requires around 300 to 400 MJ (8 to 10 L diesel) to produce and emit between 3 and 15 kg CO₂-e. Insecticides consume 250 to 350 MJ per kg active (6.5 to 9 l diesel) and emit between 3 and 10 kg CO₂-e

On-farm indirect energy use embodied in agro chemicals is a significant part of the energy and cost budgets. Cost is strongly linked to energy price. Using the approach detailed in this document it is possible, if desired, to measure not only diesel, electricity and other sources of direct energy but fertiliser and chemical use as well.

Conversion Factors

Different sources of energy are measured in different units. Diesel, for example, is purchased in litres while electricity is purchased in kilowatt hours, [kWh]. Once the auditor has collected totals for various energy sources, each of these must be converted to joules, or mega-joules, to derive total energy.

Table 1, below provides conversion factors to complete this. In addition, each energy source will emit different amounts of greenhouse gasses, expressed as kilogram of CO₂-e.

The embodied energy and greenhouse gas (GHG) per unit of energy source presented in Table 1 are those published by the Department of Climate Change and Energy Efficiency (ISBN, online version 978-1-922003-51-5).

Source	Embodied energy		Greenhouse gasses	
Diesel	38.6	MJ/litre	2.68	kg CO ₂ -e/L
Biodiesel	34.6	MJ/litre	0.12	kg CO ₂ -e/L
B20	37.8	MJ/litre	2.17	kg CO ₂ -e/L
ULP	34.2	MJ/litre	2.29	kg CO ₂ -e/L
LPG	25.7	MJ/litre	1.54	kg CO ₂ -e/L
Electricity NSW	3.6	MJ/kW.hr	0.88	kg CO ₂ -e/kw.hr
Electricity Qld	3.6	MJ/kW.hr	0.86	kg CO ₂ -e/kw.hr
Aviation Kerosene	36.8	MJ/kW.hr	2.56	kg CO ₂ -e/L

Table 1: Embodied energy and GHG emissions for different energy sources.

Of course the third element of energy audits is the cost of energy. The gross cost of each energy source should be taken from farm records.

Level One Methodology

A level one audit calculates total energy consumed expressed per unit of production and per farmed hectare. To derive a Level One energy audit, a list of commodities produced during the review period with associated production (bales, tonnes, other units) and farmed areas are collected from farm records. Similarly, total energy consumption is collated from invoices for each energy source (diesel, petrol, other fuels and electricity).

Using conversion factors stated in Table 1, the total of each energy source is converted into mega-joules of energy, kilograms of CO₂-e and cost. All energy sources are totalled to derive the grand total energy, CO₂-e and cost. The grand totals for each of these three units are then divided by the total farmed area and by total production to derive the energy insensitivities of the site.

In summary, the following information needs to be collected:

- Background farm information and description of the enterprise (Eg. Cotton, wheat and cattle production, Warren NSW);
- Definition of the review period (Eg 1 Sep 12 to 31 Aug 13);
- Details of the season, very wet or dry. If desired, rainfall and temperature statistics can be found at bom.gov.au/climate/data/ and selecting 'Weather & climate' and 'monthly' from section 1;
- List of production for the review period with associated tonnes (or bales) and areas. Note that fallow should be included as a line item to account for any fallow management;
- A list of all direct energies consumed on farm (typically diesel, electricity and ULP) with associated quantities and costs. This information is generally obtained either from invoices or from the farm accounting system; and
- Opening and closing stocks of all fuels if available.

Level one error rates

It is important to calculate not only the actual values but the likely range of error associated with each measurement. This section provides a guide to achieve this and includes an example error calculation.

Farm records are used to obtain a list of crops with associated arable areas and production. These are derived from quantities that are reliably measured, such as tonnes of grain delivered, bales ginned and litres of diesel purchased. Production areas are generally derived from knowledge of paddock dimensions, hectare meters on various machines and GPS methods. While all of these quantities are known reasonably well, there is some error associated with the measurement of each of these quantities.

The total litres of diesel purchased during the review period is derived from purchase invoices and/or farm accounting software. For each delivery, diesel is measured out of the truck via a calibrated meter so we can assume that differences between invoiced amount and actual amount is negligible and can be ignored. Importantly, we make the assumption that all of the diesel that was purchased in the review period was used in the review period. This is a correct assumption except for variances in opening and closing stocks. In other words, while a certain amount of diesel was purchased, we may have actually used less diesel than this as there was more diesel in storage at the end of the season than there was at the start. Conversely, if there was less diesel in storage at the end of the season than there was at the start, we would have used more than our litres purchase.

If, for the sake of an example, we say that: 200,000 litres of diesel were purchased for the season at a total cost, net of rebate, of \$220,000. No opening and closing stocks of diesel were kept. That is litres stored in the tank at the beginning and end of each season are unknown. We will also assume for this example that the storage tank has a volume of 10,000 litres.

Our estimate of 200,000 litres of fuel used for the season could be out by the $\pm 10,000$ litres potential storage volume. Our potential error is then $10,000 \div 200,000 = 5\%$.

Input	Quantity		Error %
Diesel	200,000	L	5%

For the same season we purchased 10,000 litres of ULP at a cost of \$11,000. The ULP tank has a volume of 5,000 litres and we do not know opening and closing stocks. Thus we can calculate the following:

Input	Quantity		Error %
Diesel	200,000	L	5%
ULP	10,000	L	50%

We also purchased 60,000 kW.hr of electricity at a cost of \$15,000. This supply is accurately metered and we can assume that the errors associated with the electricity meter are negligible. (This is the same as the meter errors associated with diesel and with ULP measurement.)

Input	Quantity		Error %
Diesel	200,000	L	5%
ULP	10,000	L	50%
Electricity	60,000	kWh	-

What we are really interested in measuring is total energy. While there is a large uncertainty surrounding the amount of ULP used, it only makes a small contribution to total energy. Therefore the error associated with measuring ULP will have a smaller contribution to the error associated with total energy. To explain this further, let's go ahead and use the conversion factors in Table 1 to calculate total energy consumption for our example farm.

Input	Quantity		Error %	MJ
Diesel	200,000	L	5%	7,720,000
ULP	10,000	L	50%	342,000
Electricity	60,000	kWh	-	216,000
				8,278,000

In the next step we calculate how much each energy source contributes to total on-farm, direct energy consumption. Diesel provides the largest share of total energy and ULP and electricity provide smaller amounts of energy. This means that when we design our measurement system we need to concentrate on measuring diesel very well and that ULP and electricity are less important.

Input	Quantity		Error %	MJ Total	MJ %
Diesel	200,000	L	5%	7,720,000	93%
ULP	10,000	L	50%	342,000	4%
Electricity	60,000	kWh	-	216,000	3%
				8,278,000	

In this final step we calculate the contribution which each energy source makes to the measurement error of total energy. Note that all errors are \pm errors.

Input	Quantity		Error %	MJ Total	MJ %	Total error
Diesel	200,000	L	5%	7,720,000	93%	4.7%
ULP	10,000	L	50%	342,000	4%	2.1%
Electricity	60,000	kWh	-	216,000	3%	-
				8,278,000		6.7%

That is, total energy is 8,278,000 MJ \pm 7%.

Total energy will depend on farm size and production. To enable comparison between farms and between seasons total, energy use is expressed per hectare and per bale, that is, MJ per Ha and MJ per bale. There are errors in the measurements of total production and total area which will add to the total in the ratios MJ per Ha and MJ per bale.

Because cotton lint is sold by weight, measurement of the weight of a bale of lint is done to a high level of accuracy. Like the metering of diesel, ULP and electricity this measurement error is small error can be ignored.

Areas of cotton production are generally well known through the use of GPS equipment as well as acre meters on various machines. It is prudent to question the farmer as to how production area is known and to ensure that an exact number is supplied, rather than an approximate or 'rough' number. Generally farmers will have used GPS survey or other GPS equipment in the life of the field to accurately measure field area. Similarly, errors in the measurement of productive area are small and can be ignored.

Assuming that farmed area has been accurately measured, we can now conclude that for our example farm we have measured total direct, on-farm energy consumption to within \pm 7%. Note that we do not report this error past a whole number because we only have a low level of precision. We can also recommend that if opening and closing stocks of diesel are measured at the start and end of each season then accuracy will be greatly improved and similar measurement for ULP would add to the level of accuracy. For the sake of completeness, GHG and costs for the above example are calculated below.

Input	Quantity		MJ Total	Kg CO ₂ -e	\$
Diesel	200,000	L	7,720,000	536,000	220,000
ULP	10,000	L	342,000	22,900	11,000
Electricity	60,000	kWh	216,000	49,200	15,000
TOTAL			8,278,000	608,100	246,000

If opening and closing stocks of diesel (or ULP or other commodity) is known, it is reasonable to assume that this quantity is measured to an error of \pm 0.5%. If opening and closing stocks of diesel and ULP are both known, the total error for this example is \pm 1% as calculated below.

Input	Quantity		Error %	MJ Total	MJ %	Total error
Diesel	200,000	L	0.5%	7,720,000	93%	0.5%
ULP	10,000	L	0.5%	342,000	4%	0.0%
Electricity	60,000	kWh	-	216,000	3%	-
				8,278,000		0.5%

Finally, electricity invoice dates generally do not coincide exactly with the review period. Simply collecting the invoices coinciding most closely with the review period is generally acceptable.

Mixed farming operations

A level one audit is straightforward where there is only one commodity produced. Often there is more than one product grown on the farm and a level one audit is not able to discern how much energy went into each enterprise. For example, a cotton farm might also produce wheat. For a given season, it is unknown, for a level one analysis, how much of the total energy went to cotton production (to give MJ per bale) and how much went to wheat production (to give MJ per tonne). In these cases, a level two analysis is performed and then amalgamated back up to a level one analysis. In this case, the level one analysis will have the same error as the level two analysis.

Level Two Methodology

Level two energy audits aim to disaggregate total energy use and itemise energy used in each farming operation. Available records vary widely between farms. A Level Two audit will usually consist of a fuel bowser and electricity meter-box type measurement for all processes with considerable farmer interviews. Various methods can be used to measure energy use to a sufficient level of detail for a level two audit and are discussed below. Suffice to say there is no standard approach, and all cases require different assumptions. The steps below will provide the reviewer with a guide to measuring level two energy assessment.

A level one assessment is always performed with a level two analysis because:

1. This will provide a baseline for the level two analysis. In other words, knowing the total diesel consumption for the season will provide a measured comparison for the total diesel consumption determined from a level two analysis.
2. A level one analysis will provide the relative amounts of energy obtained from various sources and therefore the measurement effort required for each of these. For example, electricity will be a very minor portion of total energy on farms where electricity is used only for domestic and workshop requirements. In this case, total electricity use will be generally distributed per hectare and no other measurements are necessary. Conversely, electricity use will be a much more significant portion of the total on farms that use electric pumps. In this case electricity use must be accounted for in more detail.
3. Provide gross production figures.

In other words, all the information listed in the dot points in the section *Level One Methodology* is also required for a level two analysis.

Equipment List

In addition to this list, a list of machinery used during the review period will need to be collected.

Powered machinery

This list will include all trucks, tractors, vehicles and any major plant. Include irrigation plant in this list. Minor plant, such as grain augers, mobile welders etc. can generally be grouped under one 'minor plant' heading.

- Make and model (e.g. 'Toyota FJ62' or 'JD9440')
- Year model
- Fuel source (diesel, ULP, LPG or other)
- Description

Implements

- Description (eg Janke Planter #1). Include any implement-specific details, such as tank volume for sprayers.
- Swath width
- Associated tractor
- Typical or nominal ground speed

Contractors

Any contract operations need to be accounted for. Ideally, fuel use by contractors should be measured. However, this is not always possible so estimation techniques, discussed below, can be used.

Measurement of Diesel use

Diesel is a very significant source of direct, on-farm energy on cotton farms and therefore needs to be measured with accuracy and detail.

The following steps will provide a robust measurement of itemised diesel use.

- At the start of each season take a reading of the volume in each storage tank.
- Keep all of your fuel delivery dockets or other statement showing fuel delivered.
- Using a meter on each fuel trailer to provide an accurate measurement of your energy use.
- Record the following things:
 - a. Date.
 - b. Litres pumped.
 - c. Machine (e.g. 'old Toyota' or 'JD9440').
 - d. Engine hours or kilometres at the time of the fill.
 - e. Operation. (You should have already defined what categories you will use and what fits into them as part of your benchmarking process.)
 - f. Crop

There are many suppliers of fuel meters and it is important to discuss exact requirements with your supplier. One example, suitable for an overhead tank, is the McNaught 1-inch fuel meter for 10 to 100 L/min, model F025-1S3 with mechanical rolling numbers and reset button retails for \$1,200 incl. GST. Be aware that this an example only; it may not suit all overhead tanks and diesel bowers with fuel pumps would require a different model of fuel meter.

Processing the logbook data into useable information is not difficult. Once data has been entered from a fuel logbook it is a reasonably straightforward process to produce a report showing how much diesel is used for each activity. It is possible to have an accounting firm, a secretariat or similar organisation to provide these analyses.

GPS systems and the measurement of diesel use.

Machinery manufacturers and third party suppliers provide a range of systems that measure and record fuel use in tractors, pickers and other machines. The primary limitation of both the GreenStar and the CASE IH equivalent system is that fuel use at the ends of the field is not recorded. Also fuel use where machines stop in the middle of a run or for any other reason, such as travelling is not recorded. This underestimates total fuel use in the 10 to 15%. While these systems are an excellent tool for level three assessments and provide excellent, useful information, they are not suited to measuring total fuel use.

Recently, data communications and reporting have made substantial improvements for in-field machines such as tractors, pickers and harvesters. Both CASE IH and John Deere now offer telemetry systems where a machine owner can log onto a web portal and download information from the machine (tractor, harvester or other) via a modem installed on the machine. Information may include GPS location and date/time stamp with fuel use, yield information, coolant temperature; in fact, information from any sensor on the machine.

Initial discussions with both the John Deere and CASE IH call centres indicate that their telemetry systems are capable of reporting fuel use. Both have indicated that it should be possible to get total fuel use for all compatible machinery. It could therefore be possible to use the latest telemetry systems to measure total in-field fuel use. This requires confirmation of the exact idiosyncrasies of each system. Obviously, it would also require all machines to be fitted with this technology.

Synthesis of diesel use where no records existed

Measuring energy used in individual operations will quantify energy use and provide a reasonable estimate of the associated errors. In doing so, such a method will identify nuances of individual farms, which is critical to the later steps where this information is analysed to produce recommendations. It is often the case that while there is ample level one information (fuel receipts) there are no records that itemise fuel used in individual operations. Where no data exists it is possible to estimate level two energy use by using default values. While these results can only be described as 'best-guess', they are generally adequate to make conclusions as to energy use and energy saving opportunities.

While it is clearly preferable to measure energy use it is possible to estimate energy use using default values. There are two methods for doing this:

1. Use EnergyCalc – it has the method below and all of this expert knowledge included, or,
2. Follow the method described below.

This method is essentially to estimate, for each operation by each piece of equipment, an hourly fuel burn rate and multiply that by an estimate of seasonal hours of usage. Total fuel use is then derived by adding fuel estimated for every item. For each operation:

$$\text{Fuel use [l]} = \text{Hourly FBR} \times \text{Engine hours}$$

Estimating hourly fuel burn rate

For each machine, a fuel burn rates was sourced from The Nebraska Tractor Test Laboratory <http://tractortestlab.unl.edu/testreports.htm> and other relevant sites, which provides hourly fuel burn rates at maximum load. A typical per cent of full load factor was also assumed and applied to the maximum fuel burn rate for each operation to estimate an hourly fuel burn rate. This factor is generally derived from expert knowledge and/or grower estimate.

Estimating hours worked

A list of operations and associated machines should have already been obtained. For each of these operations, typical swath width and ground speed are collected from grower knowledge. Using some basic arithmetic it is possible to calculate from these numbers hectares covered per hour.

$$\text{hectares per hour} = \text{swath width [m]} \times \text{ground speed[km/h]} \times 10$$

However, this does not account for time spent turning at the ends of the rows and other down time. Operations such as offset discs are more efficient as they turn quickly and there is no other real downtime. Operations such as planting are less efficient as the planter not only needs to turn at the ends of the field but regularly requires filling with seed.

$$\text{hectares per hour} = \text{swath width [m]} \times \text{ground speed[km/h]} \times 10 \times \text{fieldeficiency}$$

A list of operations and associated field efficiencies can be found in *Estimating Field Capacity*. (Iowa State University Extension. PM 696 Revised April 2001.)

Given that we already know the total hectares covered for this operation (just check that the total area was covered as sometimes it is not) and the hectares covered per hour we can calculate the total engine hours for this operation.

$$\text{Engine hours} = \text{Hectares covered [Ha]} \div \text{hectares per hour [Ha/h]}$$

Transport fuel

To itemise diesel used in heavy vehicle transport, total fuel is first calculated. Seasonal kilometres travelled are generally collected for each vehicle from maintenance records (or a grower estimate if there are no records). Fuel use, in litres per kilometre, per 100 km or other unit, is normally estimated by the farmer. Otherwise, manufacturer information can be sourced via the internet. Once total fuel is estimated it is distributed to each activity, e.g. fertiliser carting, module carting, etc., based on a grower estimate of relative use. Diesel use can further distributed to particular crops on a per hectare basis. For example, the farmer might state that “I know that we bought in four loads of fert for the dryland crops.” This use is then distributed to each crop per hectare of production.

Light Vehicle fuel

Diesel used in light vehicles is generally small and can be estimated using seasonal kilometres travelled (either from maintenance records or a farmer estimate) multiplied by the manufacturer’s stated fuel burn rate (sourced via the internet).

Calculating total diesel use

Total fuel use is the grand sum of each operation plus transport fuel, vehicle fuel and all other fuel use.

Once this is complete, compare your total with the known total fuel used from your level one analysis. Adjust if necessary. Report the difference between the estimate of fuel use from this level two method and the known diesel use from the level one analysis.

$$\text{Error} = \pm \frac{\text{Total fuel from Level One} - \text{Total Fuel from Level Two}}{\text{Total fuel from Level One}} \times 100\%$$

Measuring electrical energy

A level one analysis should identify the relative contribution of electricity to the total energy use and this should guide the degree of measurement required. Two scenarios are discussed below, one where electricity is a minor component and one where electricity is a significant contributor.

Workshop and domestic electricity supply

Electricity will be a minor portion of total energy on farms where electricity is used only for domestic and workshop requirements. In this case, total electricity use represents an overhead cost and can be distributed to each commodity produced on a per hectare basis and no other measurements are necessary. Within each commodity there will be multiple operations (seeding, spraying, harvesting etc) and electricity use proportioned to that crop will need to be further distributed to each operation. Electricity use proportioned to a particular crop is generally distributed to operations within that crop on a per hectare covered basis.

Pumping electricity

Electricity consumed for pumping will be a far more significant cost to the enterprise - pumping is typically 60% to 75% of total direct energy consumption. Energy used in electrically driven pumps will certainly need to be quantified for a level two analysis.

Generally electrical pumps have their own meter and pumping energy is simply derived from the electricity invoices. Sometime multiple pumps are on the same meter and they can generally be grouped as one item.

Sometimes pumps do not have their own meter and are shared with workshop and other uses such as other enterprises. In these cases or when it is simply desired to itemise this energy use, a method congruent with fuel use estimation, described above, is used.

$$\text{Total energy consumption [kW.h]} = \text{hourly power consumption [kW]} \times \text{hoursof operation}$$

To calculate the hourly consumption of electricity the auditor will need to visit each pump site to inspect the manufacturer's plate on each motor to derive maximum rated engine power. (It is a good idea to take a photo of the plate.)

The plate will normally state rated output power for the motor. (1 kW = 1.341 horsepower.) Electric motors are never 100% efficient and will consume more electrical power than they produce in mechanical power. Thus, power consumption will be given by:

$$\frac{\text{stated output power}}{\text{stated motor efficiency}}$$

Actual motor efficiency varies between motors and may range from 75% to 95%. Motor efficiency also varies with motor load and speed. Three phase, or 415 V, electric motors are most commonly used for pumping and are currently regulated for Minimum Energy Performance Standards (MEPS). MEPS for electric motors was first introduced in October 2001 (MEPS 1) in Australia, and 2002 in New Zealand. The levels were upgraded in 2006 (MEPS 2) in both countries. (See AS/NZS 1359.5-2004 for more information.) If motor efficiency is not otherwise stated, for new motors assume the following values and for old motors use the following values less 5%.

Power [hp]	Minimum Nominal Efficiency
1 - 4	78.8
5 - 9	84
10 - 19	85.5
20 - 49	88.5
50 - 99	90.2
100 - 124	91.7
> 125	92.4

Table 2: MEPS2 minimum electrical motor efficiencies.

This is maximum continuous power consumption; actual use depends on the applied load. A % of full load factor is estimated from expert knowledge of the pump system.

$$\text{Actual hourly power consumption [kW]} = \frac{\text{stated output power}}{\text{stated motor efficiency}} \times \% \text{ of full load}$$

This value really can be anything from a low 10% to 100%. If you are itemising power between multiple pumps, simply assume 100% for each pump.

Remember, you will also need to estimate hours of use, usually from grower knowledge but sometimes from service records.

$$\text{Total energy consumption [kW.h]} = \text{hourly power consumption [kW]} \times \text{hoursof operation}$$

Measurement of ULP, LPG and other fuels

Use of ULP, LPG and other fuels is generally minor. If total use is small, it is acceptable to distribute these energies per hectare similarly to minor electrical use. If there is/are particular item(s) that consume significant amounts of ULP then this use can be estimated using

$$\text{estimated hourly fuel burn rate} \times \text{estimated hours of use}$$

Level Three Analysis

A level three energy audit aims to accurately measure energy usage within a specific operation. Typically, level three audits focus where the greatest energy consumption or greatest potential gains have been identified from a level two audit. Level three audits are more advanced as they involve consideration of sensors, measurement techniques and data storage, transmission and analysis. Level three audits are outside the scope of this report.

Recommendations

Measuring energy use is relatively easy. The hard question is what to do to reduce energy consumption and/or cost? Farmers are generally resourceful and efficient and there are usually few easy gains.

An itemised energy assessment is an important piece of the puzzle. It enables an auditor to identify where energy is being used. It enables participation in benchmarking studies which can help identify where energy consumption is higher than normal. Energy measurement identifies the size of each cost area and therefore the relative gains of any improvement. Once the audit has been conducted and reports generated, as outlined below, it is necessary to analyse the information from the audit to determine strategies to reduce energy use. To reduce the complexity of analysing the system, energy recommendations for each audit should be examined for alternatives in:

1. Energy source (fuel switching),
 - diesel gas injection on pumps ≈10% cost savings and energy savings
 - alternatives such as biodiesel
 - other fuel switching.
2. Tariffs and costs, which aims to reduce the cost of the existing energy.
 - Energy brokers and contracts
 - Wholesale electricity supply
 - Analysis of current and optional electricity tariffs
 - Bulk purchase (grower cooperatives?) of diesel, fertiliser and chemical
3. Energy Demand, which looks at practice or infrastructure change or refinement.
 - Water pumping
 - Precision spray systems
 - Nutrient management
 - Precision irrigation systems
 - Tractor fuel efficiency
 - Light vehicles

Water pumping

Pump efficiencies will typically vary between 40 and 70%. That is, a pump that is 70% efficient will use nearly half the energy compared to a 40% efficient pump to lift the same volume of water over the same height.

Pump efficiencies are an area where gains might be possible. Many pumps have been changed ad hoc over the years and many were never designed properly in the first instance. Additionally many pumping installations are ageing and have high levels of wear.

Pumps are a ‘forgotten’ part of the energy equation. Farmers will usually aim to have the latest tractors with on-board engine management and traction management systems that get the best out of every litre of diesel. Many have systems that communicate with the grower in real time. Conversely, typically pumps have little in the way of engine or pump management systems; they are often largely forgotten. Tail water return pumps are particularly prone to these factors. However, pumping is 40 to 70% of the total direct on-farm energy bill.

Diesel verses electric?

The following table looks at the cost of a unit of energy for diesel and electricity and how well this is converted to output mechanical energy by the respective motors. One litre of diesel costs \$1.35 (in this scenario) and provides 38.6 MJ of energy. One kilowatt-hour of electricity costs 24.4 cents (in this scenario) and provides 3.6 MJ of energy. The efficiency of converting this energy to useable mechanical power varies with the type of motor. Diesel motors output 35% to 45% of the power they consume from the input fuel and electric motors convert 75% to 95% of the power they consume. From these assumptions the cost of useable, output mechanical power is derived in the final column.

	Unit	\$/unit	MJ/unit	Energy cost cents/MJ	Engine efficiency	Cents /output MJ
Old diesel motor	L	1.41	38.6	3.65	35%	10.4
Modern diesel	L	1.41	38.6	3.65	45%	8.1
Old ULP motor	L	1.33	34.9	3.81	28%	13.6
Modern ULP	L	1.33	34.9	3.81	36%	10.6
Electric motor	kW.hr	0.24	3.6	6.76	85%	9.0
Electric motor	kW.hr	0.24	3.6	6.76	92%	7.1

Table 3: Comparison between diesel and electrical motor efficiencies.

Electrical tariffs must be closely examined. Be especially careful with any tariff that includes a ‘peak demand’ charge. The auditor must also consider the likely future rises in the cost of wholesale and retail electricity.

Reporting

The auditor should follow a standard report format. Again, EnergyCalc provides a standard report with little effort. The report should include the following information:

1. Grower Details
 - Name and contact details.

- Farm
- 2. State conversion factors (as per Table 1.)
- 3. Production details – list all crops and associated areas and production.
- 4. Level one, summary, energy use for each crop
 - Include MJ, CO₂-e and \$ per hectare and per unit of production.
- 5. Tractor and machinery inputs for each crop
 - Basically a crop diary so that the grower can confirm the input data
- 6. Pumping energy inputs.
- 7. Vehicle energy inputs.

This information may also be expressed in other ways and with charts.

Appendix B: EnergyCalc Users' Manual



EnergyCalc

User Manual

**National Centre for Engineering in Agriculture
University of Southern Queensland
Toowoomba**

**NCEA Publication 1002974/3
July 2009**



Disclaimer

While the National Centre for Engineering in Agriculture and the authors have prepared this software and document in good faith, consulting widely, exercising all due care and attention, no representation or warranty, express or implied, is made as to the accuracy, completeness or fitness of the software or document in respect of any user's circumstances. Users of the software or document should undertake their own quality controls, standards, safety procedures and seek appropriate expert advice where necessary in relation to their particular situation or equipment. Any representation, statement, opinion or advice, expressed or implied in this publication is made in good faith and on the basis that the National Centre for Engineering in Agriculture, its agents and employees, are not liable (whether by reason of negligence, lack of care or otherwise) to any person for any damage or loss whatsoever which has occurred or may occur in relation to that person taking or not taking (as the case may be) action in respect of any representation, statement or advice referred to above.

Printed in July 2009 by the National Centre for Engineering in Agriculture, Toowoomba. Material from this publication may not be used unless prior written approval has been obtained from the National Centre for Engineering in Agriculture.

This document should be cited as follows:

Baillie, C. , Zhao, B. and Agustina, L. (2009). EnergyCalc, User Manual. National Centre for Engineering in Agriculture Publication (1002974/3), USQ, Toowoomba.

This user manual accompanies the EnergyCalc website and database tools. Software programming was undertaken by Bo Zhao.

Acknowledgements

This work was partially funded by the Queensland Government as part of the South-East Queensland Irrigation Futures project (SEQIF).

Contents

1. Introduction.....	1
2. Access, permissions and security.....	1
3. Navigating the system.....	2
3.1 Browser navigation issues.....	2
3.2 Administrative function and Home Page.....	2
3.3 Data entry	3
3.3.1 Assessment and crop/product.....	3
3.3.2 Calculation, Practices and Report.....	5
4. Further Assistance.....	8

1. Introduction

EnergyCalc consists of an on-line data entry interface that links to a database hosted on a centralised server. EnergyCalc assesses direct on-farm energy use, costs and the greenhouse gas emissions (GHGs) associated with diesel, petrol, LPG and Electricity consumption. EnergyCalc examines energy use across key processes within a production system and can be used to evaluate farming practices such as tillage, spraying, irrigation etc. EnergyCalc collates all the necessary user inputs that will be used for generating assessment(s).

2. Access, permissions and security

Access to EnergyCalc is controlled via a secure login page from KMSI Portal (Figure 1).

The screenshot shows the KMSI Portal interface. At the top left is the KMSI logo (Knowledge Management System for Irrigation) and the NCEA logo. Below the logos is a navigation menu with tabs: All software, Farm dams, Irrigation assessment, Irrigation and crop records, Mapping, Energy use and GHG's, and Benchmarking. The 'Energy use and GHG's' tab is selected, and the 'EnergyCalc' tool icon is highlighted with a red circle and arrow. A red arrow points to the 'Login' link in the top right corner. Text on the left side of the image reads: 'Access to tool by clicking EnergyCalc icon after login is successful'. Text on the right side of the image reads: 'Login' with a red arrow pointing to the 'Login' link.

Access to tool by clicking EnergyCalc icon after login is successful

KMSI is the Knowledge Management System for Irrigation, developed by the National Centre for Engineering in Agriculture with funds provided by the Queensland Government as part of the South East Queensland Irrigation Futures project.

[Login](#) ← Login

All software Farm dams Irrigation assessment Irrigation and crop records Mapping Energy use and GHG's Benchmarking

EnergyCalc
EnergyCalc assesses direct on-farm energy use, costs and the greenhouse gas emissions (GHGs) associated with diesel, petrol, LPG and Electricity consumption. EnergyCalc examines energy use across key processes within a production system and can be used to evaluate farming practices such as tillage, spraying, irrigation etc.

Figure 1: Access to EnergyCalc via KMSI Portal

Once login is successful, user may navigate to EnergyCalc page by clicking EnergyCalc icon. “Logout”, “Change Password” and “Change Particular” links will also be displayed in KMSI Portal interface once login is successful. Users may edit their own user details and change their passwords by clicking the respective link (Figure 2).



Figure 2: Change Password section

3. Navigating the system

3.1 Browser navigation issues

Note that due to the vagaries of some web browsers (i.e. Explorer) using a back arrow key on a page where the cursor is not active within a data entry cell may result in the system going back to the previously viewed page without saving the entered data. Hence, *care is especially required when trying to delete data within a data entry cell by repeated use of the back space key*. Possible strategies to minimise this inconvenience include highlighting the data and using the delete key or placing the cursor at the start of cell and using the delete key.

3.2 Administrative function and Home Page

Upon clicking EnergyCalc icon from KMSI portal, users will be directed to EnergyCalc Home Page. The administrative function bar is located on top of page indicated by 'username' (Figure 3).

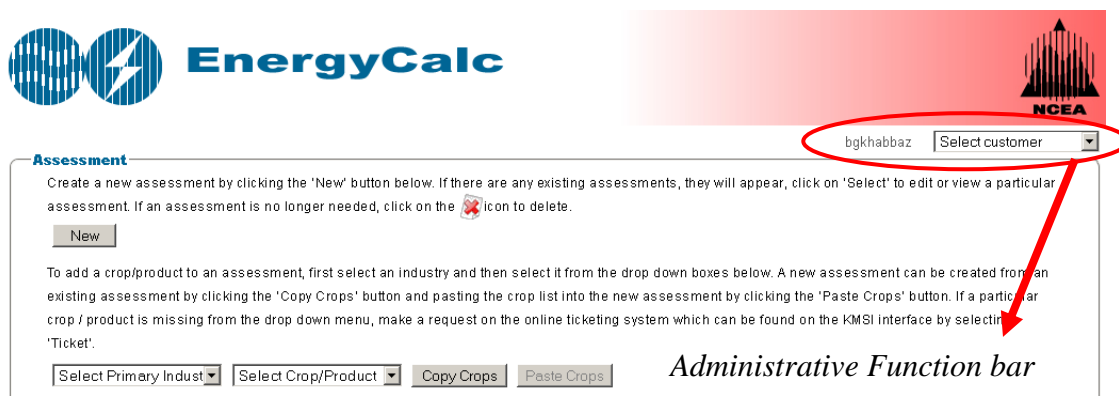

Figure 3: Administration Function and Home Page

The drop down menu will be shown if the user is manager. It is used to display the assessments of a particular user under their management.

The link on the username will only be enabled if the user is manager. Clicking the link will direct the managers to the page for adding / updating users under their management (Figure 4).

The screenshot shows the 'Edit' user management interface. At the top left is the EnergyCalc logo. At the top right is the NCEA logo with a 'Back' link. The main form area is titled 'Edit' and contains the following fields:

- Select customer (dropdown menu)
- User Name: [text input]
- Password: [text input]
- Description: [text input]
- Contact Name: [text input]
- Home Phone: [text input]
- Work Phone: [text input]
- Mobile: [text input]
- Email: [text input]
- Nearest Town: [text input]
- State: [dropdown menu labeled 'Select State']
- Postal Address: [text input]
- Postcode: [text input]

A 'Save Change' button is located at the bottom left of the form.

Figure 4: Add/Update user page for Manager

To add new user, select “Select customer” from the drop down menu and proceed to add the user information before clicking “Save Change” button. To edit existing user information, select the user name from drop down menu. Upon selecting, selected user information will be populated to the respective textboxes. Proceed to change the user information before clicking “Save Change” button.

3.3 Data entry

There are two main sections users can refer to in order to create and view a complete assessment. They are:

- Assessment details and crop / product section
- Calculation, Practice and Report

3.3.1 Assessment and crop/product

Assessment

To create a new assessment, simply click on ‘New’ button and a new row will be added to the assessment table (Figure 5). Simply fill in the necessary input details for that new assessment.

Assessment

Create a new assessment by clicking the 'New' button below. If there are any existing assessments, they will appear, click on 'Select' to edit or view a particular assessment. If an assessment is no longer needed, click on the  icon to delete.

Assessment table

Assessment Name	Year	Level	Type	Select
<input type="text" value="John Hamparsum"/>	<input type="text" value="2009"/>	<input type="text" value="Level 2"/>	<input type="text" value="Actual"/>	<input type="radio"/>
<input type="text" value="cotton with default value"/>	<input type="text" value="2009"/>	<input type="text" value="Level 3"/>	<input type="text" value="Actual"/>	<input checked="" type="radio"/>
<input type="text" value="New assessment"/>	<input type="text" value="2011"/>	<input type="text" value="Level 2"/>	<input type="text" value="Actual"/>	<input type="radio"/>

To add a crop/product to an assessment, first select an industry and then select it from the drop down boxes below. A new assessment can be created from an existing assessment by clicking the 'Copy Crops' button and pasting the crop list into the new assessment by clicking the 'Paste Crops' button. If a particular crop / product is missing from the drop down menu, make a request on the online ticketing system which can be found on the KM² interface by selecting 'Ticket'.

Newly added assessment

Crop/product table

Industry	Crop/Product	Description	Area (Ha)	Production	Unit	Select
<input type="text" value="Field Crops"/>	<input type="text" value="Cotton"/>	<input type="text" value="Irrigated with default val"/>	<input type="text" value="458"/>	<input type="text" value="8.42"/>	<input type="text" value="bales/ha"/>	<input type="radio"/>

Figure 5: Assessment and crop/product table

To edit assessment detail, simply type in the new details in the relevant textboxes.

To delete an assessment, simply click on the  button of that assessment.

Crop/Product

To view the crop/product of a particular assessment, select that assessment by simply clicking on the radio button () of that assessment under the 'Select' column of the assessment table. All of the crops/products belonging to that assessment will be displayed on the crop/product table.

To add crop/product to the assessment, simply select a particular assessment, followed by selecting a primary industry from 'Select Primary Industry' drop down menu and after that select a crop/product from 'Select Crop/Product' drop down list. List items for 'Select crop/product' drop down menu will be auto-populated based on the selected industry. Upon selecting the crop/product, a new row will be added to the crop/product table. User may proceed to filling in the necessary information in the relevant textboxes.



Users may add crop/product to the selected assessment as many as they wish. Every time the users add a crop/product to the assessment, the new crop/product will be added to the crop/product table that (Figure 5). User may proceed to fill in the necessary crop/product information. To delete a particular crop/product from the assessment, simply click on the  button of that crop/product.

Users may also copy the crops/products and all of the practices contents from one assessment to other assessment. Simply select on the assessment to copy by clicking on the radio button () of the relevant assessment and then click on "Copy Crops". User should then proceed to select the assessment of which the crops/practices are to be copied to by clicking on the radio button () of the relevant assessment and after

that click on “Paste Crops” button. The copied crops will appear in the crop table and the copied practices will appear in the practice table.



3.3.2 Calculation, Practices and Report



To begin assessment to a particular crop/product, simply click on the radio button () of that crop/product under the ‘Select’ column of the crop/product table (Figure 5). Upon clicking the radio button, ‘Calculation’, ‘Practices’ and ‘Report’ sections will be displayed (Figure 6).

Users may proceed to fill in the necessary data under ‘Calculation’ section to accommodate the assessment. After all of the information has been filled in, users may proceed to click on the  button to confirm the adding. The new practice and its assessment result will appear in practice table under ‘Practices’ section. Users may choose to add as many practices as they wish by repeating the same process i.e. filling in new data under ‘Calculation’ section and click on the  button after completed.



Note that EnergyCalc also provides a number of embedded calculators to assist with calculated data entry. To use this service, simply click on the  button found under the ‘Calculation’ section.



Calculation

To add a practice to a crop, you will need to select a process, an operation and a practice. Then select an energy source, the cost of each energy source could be changed if you like. After selecting an energy input type, you can start to calculate. Click on  to load second level calculators. Click  to save or  to cancel.

Choose Practice	Energy Cost	Energy Input Tractor	
Preparation <input type="text"/>	<input type="radio"/> Diesel (litre) 1.18	Number of operation <input type="text" value="40"/> <input type="text" value="Constant"/>	
Tillage <input type="text"/>	<input checked="" type="radio"/> Petrol (litre) 1.2	Petrol used per operation <input type="text" value="250.00"/> <input type="text" value="litre"/>	
Bedforming <input type="text"/>	<input type="radio"/> Gas (litre) 0.3	Area <input type="text" value="50"/> <input type="text" value="ha"/>	
Add new practice <input type="text"/>	<input type="radio"/> Electricity (kwh) 0.1	Petrol used per ha <input type="text" value="5"/> <input type="text" value="litre/ha"/>	

Practices

To remove a practice, click on  at the beginning of the row. To modify the practice, click on .

	Practice	Energy Source	Energy Used	Standard Energy (GJ)	%	Cost (A\$)	%	Emission (Kg)	%	
		Bedforming	Petrol	10000.00 (litre)	342.00	100	12000.00	100	25000.00	100
Total	-	-	-	-	342.00	100	12000.00	100	25000.00	100

Report

To produce a report on the selected crop, click on 'report' button for PDF format or click on 'Export .csv' for CSV format. To include all crops in the report, use the other buttons named 'Export all crops .csv' and 'Report all crops.'

Figure 6: Calculation, Practices and Report section

To edit a particular practice, simply click on  button of that particular practice under the ‘Practice Section’. The information of that selected row will be re-populated in the ‘Calculation’ section. Users may then proceed to update the values under the

‘Calculation’ section and click on  button after completed or  button to cancel the edit.

To delete a particular practice from the assessment, simply click on the  button of that practice.

A Report can be generated from the ‘Report’ section after completing the assessment. A Report can be generated for multiple or all crops. Simply click on the respective button to generate the relevant report.

The generated report calculates the energy, greenhouse gas emissions and costs for particular practices entered into the calculator (Figure 7 – 10). An EnergyCalc report includes the following sections:

- Machinery inputs ie tractors, stationary motors, pumps and vehicles
- Summary of energy use
- Performance indicators
- Energy and cost savings



EnergyCalc Assessment Report

Generated by Borzoo Ghareei Khabbaz on 2/08/2011

Grower Details

Name	Wayne Reeves
Phone (Mobile)	0428 718 3
Phone (Work)	
Email	WReeves@primeag.com.au
Address	Emerald, QLD, Emerald 4720, QLD
Organisation	

Table 1 - Assessment Details

Crop	Desc	Area (ha)	Production	unit	Year	Level	Type
Cotton	Irrigated with default values	971.5	-	-	2009	3	Actual

Table 2 - Energy Source

Energy Source	Unit	Cost	Energy Conversion Factor (Unit to GJ)	Greenhouse coefficient energy to CO2 equivalent
Diesel	litre	1.18	38600000	2900000000
Petrol	litre	1.2	34200000	2500000000
Gas	litre	0.3	26200000	2560000000
Electricity	kwh	0.1	3600000	1046000000

Table 3 - Summary of Energy Usage and GHG

Crops	Energy consumed (GJ)		Energy intensity parameter	Energy intensity (GJ per ...)		Greenhouse gas emission intensity (kg CO2 per ...)		Energy cost intensity (\$ per ...)	
	Current	%		Current	Benchmark	Current	Benchmark	Current	Benchmark
Cotton	13395.82	100	per hectare	13.79		1035.95		421.52	
			per vield	Infinity		Infinity		Infinity	
Total	13395.82	100							

Figure 7: First page of energy report

Irrigated with default values - Cotton - 971.5 ha

Table 5 - MACHINERY - TRACTOR ENERGY INPUTS

Process	Operation Type	Machinery	Energy source (cost)	No. of Operation	Energy use per operation	Area (ha)	Energy source per area	Engine power	Engine load	Ground speed	Working width	Work rate
Preparation	Spraying	Chemical Application	Diesel	1	33390.00 (litre)	6678	5 (litre/ha)	-	-	-	-	-
Preparation	Spraying	Airplane Spraying	Diesel	1	45.22 (litre)	1292	0.035 (litre/ha)	-	-	-	-	-
Preparation	Tillage	Deep Ripping	Diesel	1	10728.00 (litre)	894	12 (litre/ha)	-	-	-	-	-
Preparation	Tillage	Discing	Diesel	1	13536.00 (litre)	1128	12 (litre/ha)	-	-	-	-	-
Establishment	Planting	Seeding/Planting	Diesel	1	4857.50 (litre)	971.5	5 (litre/ha)	-	-	-	-	-
Establishment	Spraying	Airplane Spraying	Diesel	1	36.77 (litre)	1050.5	0.035 (litre/ha)	-	-	-	-	-
Establishment	Spraying	Airplane Spraying	Diesel	1	5.46 (litre)	156	0.035 (litre/ha)	-	-	-	-	-
Establishment	Fertilising	AirAg Fertilizing	Diesel	1	10.92 (litre)	312	0.035 (litre/ha)	-	-	-	-	-
Establishment	Tillage	Bedforming	Diesel	1	7772.00 (litre)	971.5	8 (litre/ha)	-	-	-	-	-
In Season	Spraying	Airplane Spraying	Diesel	1	186.62 (litre)	5332	0.035 (litre/ha)	-	-	-	-	-
In Season	Tillage	Cultivate and Side Dress	Diesel	1	4360.00 (litre)	872	5 (litre/ha)	-	-	-	-	-
In Season	Fertilising	AirAg Fertilizing	Diesel	1	23.38 (litre)	668	0.035 (litre/ha)	-	-	-	-	-
Irrigation	Water Supply & Distribution	Relift	Diesel	1	220773.38 (litre)	971.5	(litre/ha)	-	-	-	-	-
Harvest	Harvesting	Cotton Picker	Diesel	1	43717.50 (litre)	971.5	45 (litre/ha)	-	-	-	-	-
Post Harvest	Crop Storage & Handling	Spraying	Diesel	1	2.24 (litre)	64	0.035 (litre/ha)	-	-	-	-	-
Post Harvest	Crop Destruction	Stalk Pulling	Diesel	1	1605.00 (litre)	321	5 (litre/ha)	-	-	-	-	-
Post Harvest	Crop Destruction	Root Cut	Diesel	1	5992.00 (litre)	749	8 (litre/ha)	-	-	-	-	-

Figure 8: Machinery – Tractor energy inputs

Irrigated with default values - Cotton - 971.5 ha

Table 6 - SUMMARY OF ENERGY USE

Machinery	Energy Source	Annual / seasonal consumption	Standard Energy (GJ)		Emission (kg)		Cost (A\$)	
			GJ	%	kg	%	\$	%
Chemical Application	Diesel	33390 (litre)	1288.85	10	96831	10	39400.2	10
Airplane Spraying	Diesel	45.22 (litre)	1.75	0	131.14	0	53.36	0
Deep Ripping	Diesel	10728 (litre)	414.1	3	31111.2	3	12659.04	3
Discing	Diesel	13536 (litre)	522.49	4	39254.4	4	15972.48	4
Seeding/Planting	Diesel	4857.5 (litre)	187.5	1	14086.75	1	5731.85	1
Airplane Spraying	Diesel	36.77 (litre)	1.42	0	106.63	0	43.39	0
Airplane Spraying	Diesel	5.46 (litre)	0.21	0	15.83	0	6.44	0
AirAg Fertilizing	Diesel	10.92 (litre)	0.42	0	31.67	0	12.89	0
Bedforming	Diesel	7772 (litre)	300	2	22538.8	2	9170.96	2
Airplane Spraying	Diesel	186.62 (litre)	7.2	0	541.2	0	220.21	0
Cultivate and Side Dress	Diesel	4360 (litre)	168.3	1	12644	1	5144.8	1
AirAg Fertilizing	Diesel	23.38 (litre)	0.9	0	67.8	0	27.59	0
Relift	Diesel	220773.38 (litre)	8521.85	64	640242.8	64	260512.59	64
Cotton Picker	Diesel	43717.5 (litre)	1687.5	13	126780.75	13	51586.65	13
Spraying	Diesel	2.24 (litre)	0.09	0	6.5	0	2.64	0
Stalk Pulling	Diesel	1605 (litre)	61.95	0	4654.5	0	1893.9	0
Root Cut	Diesel	5992 (litre)	231.29	2	17376.8	2	7070.56	2
Total	-	-	13395.82	100	1006421.77	100	409509.55	100

Figure 9: Summary of energy use

Irrigated with default values - Cotton - 971.5 ha

Table 7 - PERFORMANCE INDICATORS

Application of Energy (Processes)	Energy consumed (GJ)		Energy Intensity parameter	Energy intensity (GJ per ...)		Greenhouse gas emission intensity (kg CO2 per ...)		Energy cost intensity (\$ per ...)	
	Current	%		Current	Benchmark	Current	Benchmark	Current	Benchmark
Preparation	57699.22	17	per hectare	2.29	-	172.24	-	70.08	-
			per yield	-	-	-	-	-	-
Establishment	12682.65	4	per hectare	0.5	-	37.86	-	15.4	-
			per yield	-	-	-	-	-	-
In Season	4570	1	per hectare	0.18	-	13.64	-	5.55	-
			per yield	-	-	-	-	-	-
Irrigation	220773.38	64	per hectare	8.77	-	659.03	-	268.16	-
			per yield	-	-	-	-	-	-
Harvest	43717.5	13	per hectare	1.74	-	130.5	-	53.1	-
			per yield	-	-	-	-	-	-
Post Harvest	7599.24	2	per hectare	0.3	-	22.68	-	9.23	-
			per yield	-	-	-	-	-	-
Total	347041.99	100	per hectare	13.79	-	1035.95	-	421.52	-
			per yield	-	-	-	-	-	-

Figure 10: Performance Indicators

An important part of the report is the determination of performance indicators for the farming enterprise (Figure 10). This section of the report divides the farming system into key production processes, including preparation, establishment, in season, irrigation, harvest, post harvest and general. Energy consumed in each farming process is displayed and as a percentage of the total energy consumed. This allows users to find out which parts of the farming operations are consuming the most energy to target future energy saving initiatives. It also displays this information in terms of the intensity of energy use, greenhouse gas emissions produced and energy costs for comparative analysis.

4. Further Assistance

Your input and suggestions for improving this tool are welcome as the NCEA is constantly looking for ways to improve our products. If you have suggestions for additional features or are experiencing difficulties accessing or operating this tool, please contact:

Mr Craig Baillie
Deputy Director, National Centre for Engineering in Agriculture
University of Southern Queensland
Toowoomba Queensland 4350
AUSTRALIA
Telephone: 07 4631 2071
Email: bailliec@usq.edu.au

Appendix C: EnergyCalc Information Sheet



EnergyCalc

Craig Baillie & Borzoo Ghareei Khabbaz

A web-based software tool to assess on-farm energy use, costs and greenhouse gas emissions

National Centre for Engineering in Agriculture (NCEA) has developed an online Energy calculation tool for Agriculture called 'EnergyCalc'. EnergyCalc has been developed through funding from the Queensland Government (South East Queensland Irrigation Futures, SEQ-IF) and Cotton Research and Development Corporation (CRDC). EnergyCalc is designed to:

- Assess direct on-farm energy use, costs and greenhouse gas emissions associated with diesel, petrol, LPG and electricity consumption.
- Examine energy use within a production system.
- Evaluate farming practices such as tillage, spraying, irrigation etc.

This information generated by EnergyCalc is important for assessing the total energy consumed on farm as well as detailed energy usage for different farming practices. The software also converts the energy used within a farming systems to equivalent greenhouse gas emissions (GHGs). Total costs relating to energy consumption can also be determined and are based on updateable energy rates.



Figure 1: EnergyCalc login page.

EnergyCalc is accessible to growers, industry service providers and researchers via a secure login page on the Knowledge Management System for Irrigation (KMSI) (Figure 1).

The following is a summary of how EnergyCalc works and what it contains:

There are three main sections users need to go through in order to create a complete assessment. They are:

- Assessment details section, which is located at the top of the home page
- Adding crop / product to assessment section, which is located in the assessment details section.
- Calculation, Practice and Report sections

To add new user, select "Select customer" from the drop down menu and proceed to add the user information before clicking "Save Change" button. To edit existing user information, select the user name from drop down menu. User information will be populated to the respective textboxes. Proceed to change the user information before clicking "Save Change" button (Figure 2).

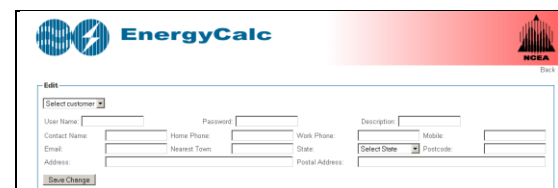

Figure 2: Add/Update user page for Manager



In this example data is shown for a cotton farm. You can add an assessment and/or a new crop to the software by using the navigation tools shown in figure 3.

To create a new assessment, simply click on the 'New' button and fill in the necessary input details for that new assessment (Figure 3).

To edit an assessment, simply type in the new details in the relevant textboxes.

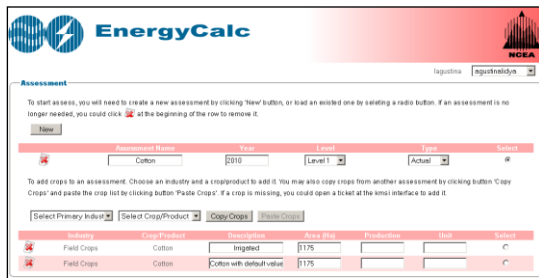
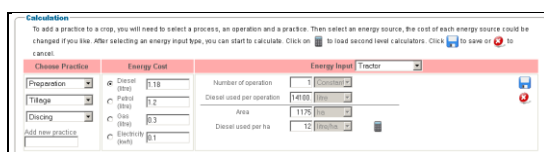

Figure 3: Assessment, Add new crop or product

Users may add a crop/product to the selected assessment, as many times as they wish. Every time a user adds a crop/product to the assessment, the selected crop/product will appear in the assessment table (Figure 3). Users may then proceed to fill in the crop/product information. To delete a particular crop/product from the assessment, simply click on delete button next to the particular crop/product.

To begin an assessment of a particular crop/product, simply click on the radio button () under 'Select' column (Figure 3). Upon clicking the radio button, 'Calculation', 'Practices' and 'Report' sections will be displayed (Figure 4).



Practice	Energy Source	Energy Used	Standard Energy (GJ)	%	Cost (A\$)	%	Emission (kg)	%
Airplane Spraying	Diesel	85.12 (litre)	3.29	0	100.44	0	246.85	0
TMS Chem	Diesel	468.00 (litre)	18.06	0	552.24	0	1357.20	0
Boom spraying	Diesel	1021.50 (litre)	39.43	0	1205.37	0	2962.35	0
Boom Spraying (weedharmer)	Diesel	67.00 (litre)	2.59	0	79.06	0	194.30	0
Fertilizer Spreading	Diesel	3651.00 (litre)	145.93	0	4308.18	0	10587.90	0
Hiller	Diesel	8413.50 (litre)	324.76	2	9927.93	2	24399.13	2
TMS Fert	Diesel	152.00 (litre)	5.87	0	179.36	0	440.80	0
Scraper	Diesel	317.00 (litre)	12.27	0	375.00	0	921.62	1
Discing	Diesel	18180.00 (litre)	701.75	3	21452.40	3	52722.00	3
Hiller	Diesel	3586.40 (litre)	138.44	0	4232.19	0	10461.14	1

Figure 4: Calculation, Practices and Report section

Users may proceed to fill in the necessary data under the 'Calculation' section to accommodate the assessment (Figure 4). After all of the information has been filled in, users may proceed to click on the (save) button which will present the result under the 'Practices' section. Users may choose to add as many practices as they wish by repeating the same process by entering new data under 'Calculation' section and click on button after completed.

Note that EnergyCalc also provides a number of embedded calculators to assist with calculated data entry. To use this service, simply click on button found under the 'Calculation' section.



To edit a particular practice, simply click on the against each practice (in the "Practices Section"). The background input data relating to the selected row will be re-populated in the 'Calculation' section (Figure 4).



Users may then proceed to update the values under the ‘Calculation’ section and click on button, after completed, or button to cancel the edit. To delete a particular practice from the assessment, simply click on button.

User may also copy all of the crops/products from one assessment to other assessment. Simply select on the assessment to copy by clicking on the radio button () of the relevant assessment and then click on “Copy Crops”. User should then proceed to select the assessment of which the crops/practices are to be copied to by clicking on the radio button () of the relevant assessment and after that click on “Paste Crops” button. The copied crops will appear on the tables (Figure 3).

A Report can be generated from the ‘Report’ section after completing the assessment. A Report can be generated for multiple or all crops.

The generated report calculates the energy, greenhouse gas emissions and costs for particular practices entered into the calculator. An EnergyCalc report includes the following sections:

- Machinery inputs ie tractors, stationary motors, pumps and vehicles
- Summary of energy use
- Performance indicators
- Energy and cost savings

MACHINERY - PUMP ENERGY INPUTS											
Process	Operation Type	Machinery	Energy source (cost)	No. of Operation	Energy use per operation (kWh)	Water used per ha (mm)	Energy source per 1000 L water	Flow rate (L/min)	Head pressure (m)	Pump efficiency (%)	Electricity per shaft (kWh)
Irrigation	Irrigation Application	Lateral Move Diesel		1	18042 (100%)	1633 (2.81 (mm))					
Irrigation	Irrigation Application	Lateral Move Diesel		1	18051 (100%)	1633 (2.81 (mm))					
Irrigation	Water Supply & Distribution	Rehdt Diesel		1	2133 (100%)						

Figure 7: Machinery - Pump energy input

SUMMARY OF ENERGY USE											
Machinery	Energy Source	Annual amount	Energy Conversion Factor (Unit to GJ)	Greenhouse coefficient energy to CO2 equivalent	Standard Energy (GJ)		Emission (kg)		Cost (\$)		
					GJ	%	kg	%	\$	%	
Ripper	Diesel	744 (100%)			28.72	0	2157.6	0	873.92	0	
Boom sprayer	Diesel	731.4 (100%)			28.23	0	2131.06	0	863.05	0	
Boom sprayer	Diesel	1031.2 (100%)			39.86	1	2996.28	1	1170.18	1	
Boom sprayer	Diesel	534.6 (100%)			19.94	0	1493.14	0	600.99	0	
Boom sprayer	Diesel	453.6 (100%)			17.81	2	13308.34	2	5374.43	2	
Shaded Sprayer	Diesel	2521 (100%)			97.87	1	7316.9	1	2974.78	1	
Shaded Sprayer	Diesel	334 (100%)			12.52	0	950.6	0	370.52	0	
Chisel Ploughing	Diesel	552 (100%)			21.31	0	1600.8	0	631.36	0	
Chisel Ploughing	Diesel	1693 (100%)			65.31	1	4906.6	1	1900.66	1	
Cultivate and Sale Dies	Diesel	1111.3 (100%)			198.08	3	14881.35	3	6053.17	3	
Cultivate and Sale Dies	Diesel	957.3 (100%)			36.96	0	2766.75	0	1129.85	0	
Cultivate and Sale Dies	Diesel	3039.3 (100%)			117.32	2	8813.97	2	3586.37	2	
Deep Ripper	Diesel	282 (100%)			10.89	0	817.8	0	332.76	0	
Discing	Diesel	1120.3 (100%)			43.35	1	3249.45	1	1317.19	1	
Landing	Diesel	3701 (100%)			146.17	2	10996.8	2	4474.56	2	
Fertiliser Spreading	Diesel	1682 (100%)			65.2	1	4998.1	1	1993.01	1	
Leveling	Diesel	14442 (100%)			576.08	8	43156	8	17629.2	8	
Limestone	Diesel	14829 (100%)			148.91	2	11263.73	2	4503.72	2	
Rolltop	Diesel	857.3 (100%)			31.17	0	2341.75	0	952.85	0	
Rolltop	Diesel	1391.6 (100%)			53.72	1	4051.04	1	1642.29	1	
Spreading (cowart)	Diesel	1024 (100%)			39.92	1	2946.4	1	1158.85	1	
Rolling	Diesel	348.8 (100%)			13.448	2	10203.6	2	4111.12	2	
Spread Fertiliser	Diesel	56 (100%)			1.85	0	146.16	0	59.47	0	
Cultivate and Sale Dies	Diesel	2082.9 (100%)			103.56	1	7760.41	1	3145.82	1	
Seedling Planter	Diesel	6039.6 (100%)			233.13	3	17514.84	3	7126.73	3	
Boom sprayer	Diesel	17 (100%)			0.46	0	34.8	0	14.16	0	
Boom sprayer	Diesel	2726.6 (100%)			278.45	4	20994.84	4	8240.73	4	
Boom sprayer	Diesel	281 (100%)			10.07	0	754.9	0	307.98	0	
Boom sprayer	Diesel	121.4 (100%)			4.84	0	363.06	0	147.97	0	
Shaded Sprayer	Diesel	1024 (100%)			39.92	1	2946.4	1	1158.85	1	
Boom sprayer	Diesel	1654.8 (100%)			63.88	1	4768.92	1	1927.66	1	
Boom sprayer	Diesel	1014.4 (100%)			62.16	1	4870.16	1	1960.17	1	
Cultivate and Sale Dies	Diesel	287.1 (100%)			11.48	0	832.99	0	336.78	0	

Figure 8: Summary of energy use



EnergyCalc
Assessment Report

Generated by Borzoo Ghareei Khabbaz on 6/8/2011

Grower Details

Name: Hamish Johnstone
 Phone (Mobile): 0428 765 1 Phone (Work):
 Email: HJohnstone@primeag.com.au
 Address: Goondiwindi, Goondiwindi 4390, QLD
 Organisation:

Assessment Details

Crop	Desc	Area (ha)	Production	unit	Year	Level	Type
Cotton	Irrigated with default values	1175	-	-	2010	3	Actual

Energy Source Costs

Diesel Cost (\$/L)	1.18	Petrol Cost (\$/L)	1.2
Gas Cost (\$/L)	0.3	Electricity Cost (\$/kWh)	0.1

Figure 5: First page of energy report

MACHINERY - TRACTOR ENERGY INPUTS											
Process	Operation Type	Machinery	Energy source (cost)	No. of Operation	Energy use per operation (kWh)	Energy source per area (kWh/ha)	Engine power (kW)	Engine load (%)	Ground speed (km/h)	Working width (m)	Work rate (ha/h)
Preparation	Tillage	Ripper	Diesel	1	744.00 (100%)	124.4 (kWh/ha)					
Preparation	Spraying	Boom sprayer	Diesel	1	731.40 (100%)	119.9 (kWh/ha)					
Preparation	Spraying	Boom sprayer	Diesel	1	1031.20 (100%)	152.2 (kWh/ha)					
Preparation	Spraying	Boom sprayer	Diesel	1	534.60 (100%)	86.1 (kWh/ha)					
Preparation	Spraying	Boom sprayer	Diesel	1	453.60 (100%)	72.91 (kWh/ha)					
Preparation	Spraying	Shaded Sprayer	Diesel	1	2521.00 (100%)	252.1 (kWh/ha)					
Preparation	Tillage	Chisel Ploughing	Diesel	1	552.00 (100%)	314.1 (kWh/ha)					
Preparation	Tillage	Chisel Ploughing	Diesel	1	1693.00 (100%)	138.4 (kWh/ha)					
Preparation	Tillage	Deep Ripper	Diesel	1	282.00 (100%)	47.0 (kWh/ha)					
Preparation	Fertilising	Fertiliser spreader	Diesel	1	1482.90 (100%)	247.1 (kWh/ha)					
Establishment	Tillage	Rolling	Diesel	1	348.80 (100%)	174.2 (kWh/ha)					
Establishment	Spraying	Spread Fertiliser	Diesel	1	56.00 (100%)	84.0 (kWh/ha)					
Establishment	Tillage	Cultivate and Sale Dies	Diesel	1	2082.90 (100%)	833.3 (kWh/ha)					
Establishment	Planting	Seedling Planter	Diesel	1	6039.60 (100%)	2137.2 (kWh/ha)					
In Season	Spraying	Boom sprayer	Diesel	1	17.00 (100%)	20.0 (kWh/ha)					
In Season	Spraying	Shaded Sprayer	Diesel	1	1024.00 (100%)	408.2 (kWh/ha)					
In Season	Spraying	Boom sprayer	Diesel	1	1654.80 (100%)	270.8 (kWh/ha)					
In Season	Spraying	Boom sprayer	Diesel	1	1014.40 (100%)	268.4 (kWh/ha)					
In Season	Tillage	Cultivate and Sale Dies	Diesel	1	287.10 (100%)	87.3 (kWh/ha)					

Figure 6: Machinery – Tractor energy inputs

PERFORMANCE INDICATORS

Application of Energy (Processes)	Energy consumed (GJ)		Energy Intensity parameter	Energy intensity (GJ per ...)		Greenhouse gas emission intensity (kg CO2 per ...)		Energy cost intensity (\$ per ...)	
	Current	%		Current	Benchmark	Current	Benchmark	Current	Benchmark
Preparation	50709.4	26	per hectare	1.2		90.05		36.64	
			per yield	9.08		682.08		277.54	
Establishment	12256.9	6	per hectare	0.29		21.77		8.86	
			per yield	2.19		164.87		67.08	
In Season	15402.6	8	per hectare	0.36		27.35		11.13	
			per yield	2.76		207.18		84.3	
Irrigation	39855.1	21	per hectare	0.94		70.78		28.8	
			per yield	7.14		536.08		218.13	
Harvest	64152	33	per hectare	1.52		113.93		46.36	
			per yield	11.49		862.9		351.11	
Post Harvest	9636.4	5	per hectare	0.23		17.11		6.96	
			per yield	1.73		129.62		52.74	
General	497.69	0	per hectare	0.01		0.88		0.36	
			per yield	0.09		6.69		2.72	
Total	192510.09	100	per hectare	4.55		341.87		139.11	
			per yield	34.47		2589.42		1053.63	

Figure 9: Performance indicators

	Forklift	Gas	200.00 (litre)	5.24	1	60.00	0	512.00	1
Total	-	-	-	544.94	100	17937.47	100	40440.38	100

Report

To produce a report on the selected crop, click on 'report' button for PDF format or click on 'Export .csv' for CSV format. To include all crops in the report, use the other buttons named 'Export all crops .csv' and 'Report all crops.'

Data Confidentiality: Data recorded and maintained in this software is stored confidentially for the purposes of the user. This data may however be aggregated or reported in a format where the identity of individuals are protected from third parties.



UNIVERSITY OF SOUTHERN QUEENSLAND
fulfilling lives



Queensland Government



SOUTH EAST QUEENSLAND IRRIGATION FUTURES SEQ-IF

Figure 10: Report selection stage

An important part of the report is the determination of performance indicators for the farming enterprise (Figure 9). This section of the report divides the farming system into key production processes, including preparation, establishment, in season, irrigation, harvest, post harvest and general. Energy consumed in each farming process is displayed and as a percentage of the total energy consumed. This allows users to find out which parts of the farming operations are consuming the most energy to target future energy saving initiatives.

Figure 9 also displays this information in terms of the intensity of energy use, greenhouse gas emissions produced and energy costs for comparative analysis.

The EnergyCalc software is able to generate reports for individual crops or for the whole farming enterprise (ie all crops). To report all crops, after creating each crop specific assessment simply click on 'Report all crops' (Figure 10)

Appendix D: EnergyCalc Input Sheet



EnergyCalc - Data Record Sheet

Field Sheet Printed by _____ on _____

Grower Details

Name _____

Phone (Mobile) _____ Phone (Work) _____

Email _____

Postal Address _____

Street Address _____

Organisation _____

Other Details

Crop type _____

Area _____ Production _____

Diesel Cost (\$/L): _____ Petrol Cost (\$/L): _____

Gas Cost (\$/L): _____ Electricity Cost (\$/kWh): _____

Motor Input Sheet

Process*	Operating*	Practice*	Energy Source (Diesel, Gas, Petrol, Electricity)	No. of Operations	Energy Use per Operation (L, kWh)	Working time per year (hr/yr)	Energy Source (L, kWh) per Hour (hr)	Work (hrs/day)	Work (days/week)	Work (Mths)	Work (Weeks)	Engine Power (kWh/hp)	Engine Load (%)
					<i>If unknown, fill in (1)</i>	<i>If unknown, fill in (2)</i>	<i>If unknown, fill in (3)</i>						

Vehicle Input Sheet

Process*	Operating*	Practice*	Energy Source (Diesel, Gas, Petrol)	No. of Operations	Energy Use per Operation (L)		Distance per year (km/yr)	Energy Source per 100 (km/L OR L/100km)
					<i>If unknown, fill in (1)</i>			

(1)

***Lists of practice possibilities**

Industry	Process	Operation	Practice			
Nursery	-Preparation	-Prepare Material	-Mixing Material -Convey Material	-Dis-infestation (Steamer)	-Propagulate Storage (Refrigeration)	Etc
		-Potting	-Potting Machine -Conveyer	-Transplanter -Lighting	-Irrigating -Spraying	-Fertigation Etc
	-Establishment	-Planting	-Planting			
		-Germination	-Refrigeration -Heating	-Lighting -Humidifying	-Cooling -Irrigating	Etc
	-In Season	-Heating	-Diesel Boiler -Diesel Heat Exchanger	-Electric Heater -Gas Heater	-Electric Water Heater -Electric Heating Mat	Etc
		-Plan Environment	-Lighting -Air Circulation	-Humidity -Evaporation Coolers	-Extraction Fans -Airconditioner	-Open/Close Storage Etc
		-Crop Maintenance	-Repotting	-Spraying	-Fertilising	Etc
	-Irrigation	-Water Supply and Distribution	-Bore -River/Creek	-Dam -Scheme	-Relift Etc	
		-Irrigation Application	-Sprinkler -Drip -Spray Stake	-Capillary -Ebb & Flow -Flood Floor	-Trough -Summer Etc	
	-Despatch	-Product Transfer	-Field Transport	-Conveyer	-Treatment	Etc
		-Detailing	-Lighting	-Cooling	-Heating	Etc
		-Road Transport	-Road Cartage	-Rail Transport	Etc	
	Field Crops AND Turf	-Preparation -Establishment -In Season	-Tillage	-Bedforming -Subsoiling (18) -Discing (12) -Chisel Ploughing (7)	-Power Harrowing (8) -Light Harrowing (4) -Weed Chipping -Inter-row Cultivating (5)	-Marking out -Regrading -Deep Ripping -Cultipacker
-Spraying			-Boom Spraying (2.2) -Airplane Spraying (0.035)	-Boom spray – followup -Pre – emergent Spray	Etc	
-Fertilising			-Fertilise Spreading (3)	-Bedforming + MAP	-Pre-cut fertilise	Etc
-Planting (only for Establishment Process)			-Conventional Drilling (5) -Direct Drilling (10)	-Specialty Planter -Sugarcane Billet Planter	-Infield Trailer -Sprigging	-Staloning Etc
-Crop Maintenance (only for In Season Process)			-Slashing (10) -Mechanical Pruning -Power Pruning	-Chipping -Flail Mower -Carting	-Mowing -Fertilising -Pre-cut fertiliser (Urea)	-Tractor Pallet Chaser -Fertiliser Spreading Etc

continue... (Field Crops AND Turf)	-Irrigation	-Water Supply and Distribution	-Bore -River/Creek	-Dam -Scheme	-Relift Etc		
		-Irrigation Application	-Surface Irrigation -Centre Pivot	-Lateral Move -Travelling Gun	-Solid Set Sprinkler Etc		
	-Harvest	-Harvesting	-Cotton Picker (45) -Cotton Stripper (11)	-Combine Harvester -Cane Harvester	-Specialty Harvester -Turf Cutting	-Inbusiness Haulage Etc	
		-Infield transport	-Infield Trailer (3) -Module Builder	-Chaser Bin -Field Bin	-Tractor Pallet Chaser Etc		
		-Road transport	-Road Cartage (0.08)	-Rail Transport	Etc		
	-Post Harvest	-Crop Storage & Handling	-Grain Drying -Grain Treatment -Cleaning	-Sorting -Spraying -Refrigeration	-Grading -Conveying -Processing	Etc	
		-Crop Destruction	-Slashing (10) -Stalk Pulling (5)	-Mulching -Root Cut	-Ripper (Pupae Bust) Etc		
	Aquaculture	-Hatchery -Processing	-Water Supply & Distribution	-Bore -River/Creek	-Dam -Scheme	-Relift Etc	
-Treatment			-Ozonator	-Steam Generator	-Lighting	-Blower, Etc	
-Cooling / Refrigeration			-Refrigeration	-Freezer	-Ice Machine	-Airconditioner, Etc	
-Heating			-Diesel Boiler -Diesel Heat Exchanger	-Gas Heater -Electric Water Heater	-Gas Cooker Etc		
-Product Transfer <i>(only for Processing Process)</i>			-Conveyer	-Bin Tipper	-Hoist	Etc	
-In Season		-Water Supply and Distribution	-Bore -River/Creek	-Dam -Scheme	-Relift Etc		
	-Aeration	-Aerator	-Force 7	-Water Circulation	Etc		
FOR ALL INDUSTRIES	-General	-Vehicles	-ATV -Utility Vehicle	-Truck -Company Vehicle	-Bobcat -Forklift	Etc	
		-Earthworks	-Excavator	-Bulldozer	-Scraper	-Grader, Etc	
		-Estate Maintenance	-Road	-Spraying	-Slashing	Etc	

Note: number in curly bracket under practice column (i.e. (10)) represents default energy used/ha

Appendix E: EnergyCalc Report



EnergyCalc Assessment Report

Generated by Craig Baillie on 19/09/2013

Grower Details

Name	
Phone (Mobile)	
Phone (Work)	
Email	
Address	
Organisation	

Table 1 - Assessment Details

Crop	Desc	Area (ha)	Production	unit	Year	Level	Type
Cotton	Irrigated	458	3856	Bales	2009	2	Actual
Wheat	Irrigated	284	519	tonnes	2009	2	Actual
Sorghum	Dryland	84	474	tonnes	2009	2	Actual
Pigeon Pea	Dryland	29	38	tonnes	2009	2	Actual
Wheat	Dryland	94	388	tonnes	2009	2	Actual
Cotton	Dryland with one irrigation	191	1566	Bales	2009	2	Actual

Table 2 - Energy Source

Energy Source	Unit	Cost	Energy Conversion Factor (Unit to GJ)	Greenhouse coefficient energy to CO2 equivalent
Diesel	litre	1.18	38.6	2.9
Petrol	litre	1.2	34.2	2.5
Gas	litre	0.3	26.2	2.56
Electricity	kwh	0.1	3.6	1.05

Table 3 - Summary of Energy Usage and GHG

Crops	Energy consumed (GJ)		Energy intensity parameter	Energy intensity (GJ per ...)		Greenhouse gas emission intensity (kg CO2 per ...)		Energy cost intensity (\$ per ...)	
	Current	%		Current	Benchmark	Current	Benchmark	Current	Benchmark
Cotton	9867.7	69.54	per hectare	21.55		5011.51		614.66	
			per yield	2.56		595.25		73.01	
Wheat	3414.72	24.07	per hectare	12.02		3207.84		337.7	
			per yield	6.58		1755.35		184.79	
Sorghum	63.7	0.45	per hectare	0.76		56.99		23.19	
			per yield	0.13		10.1		4.11	
Pigeon Pea	63.67	0.45	per hectare	2.2		164.95		67.12	
			per yield	1.68		125.88		51.22	
Wheat	95.11	0.67	per hectare	1.01		76.01		30.93	
			per yield	0.25		18.41		7.49	
Cotton	684.16	4.82	per hectare	3.58		269.11		109.5	
			per yield	0.44		32.82		13.36	
Total	14189.06	100							

Table 4 - Summary of Energy Usage

Diesel	Total Diesel Use (Litres)	Total Diesel Cost (\$)	Diesel Use (L/ha)	Diesel Cost (\$/ha)
Cotton	68768.7	81147.07	150.15	177.18
Wheat	9758.24	11514.72	34.36	40.54
Sorghum	1650.6	1947.71	19.65	23.19
Pigeon Pea	1649.52	1946.43	56.88	67.12
Wheat	2463.74	2907.21	26.21	30.93
Cotton	17723.86	20914.15	92.8	109.5

Electricity	Total Electricity Use (kWh)	Total Electricity Cost (\$)	Electricity Use (kWh/ha)	Electricity Cost (\$/ha)
Cotton	2003672.14	200367.21	4374.83	437.48
Wheat	843908.84	84390.88	2971.51	297.15

Irrigated - Cotton - 458 ha

Table 5 - MACHINERY - TRACTOR ENERGY INPUTS

Process	Operation Type	Machinery	Energy source (cost)	No. of Operation	Energy use per operation	Area (ha)	Energy source per area	Engine power	Engine load	Ground speed	Working width	Work rate
Preparation	Tillage	Alloway Stubble Bust	Diesel	1	3572.40 (litre)	458	7.80 (litre/ha)	185 (kwh)	85 (%)	9 (km/hr)	8 (m)	70 (%)
Preparation	Tillage	Discing	Diesel	2	5042.58 (litre)	458	11.01 (litre/ha)	185 (kwh)	85 (%)	8.5 (km/hr)	6 (m)	70 (%)
Preparation	Tillage	Ripper	Diesel	1	6183.00 (litre)	458	13.5 (litre/ha)	-	-	-	-	-
Preparation	Tillage	Bedforming	Diesel	1	4277.72 (litre)	458	9.34 (litre/ha)	211 (kwh)	85 (%)	8 (km/hr)	8 (m)	75 (%)
Preparation	Spraying	Boom spraying	Diesel	2	306.86 (litre)	458	0.67 (litre/ha)	165 (kwh)	50 (%)	15 (km/hr)	24 (m)	85 (%)
Preparation	Fertilising	Fertiliser Bar	Diesel	1	3595.30 (litre)	458	7.85 (litre/ha)	185 (kwh)	75 (%)	8.5 (km/hr)	8 (m)	65 (%)
Establishment	Planting	Direct Drilling	Diesel	1	2019.78 (litre)	458	4.41 (litre/ha)	165 (kwh)	50 (%)	9 (km/hr)	8 (m)	65 (%)
Establishment	Spraying	Boom spraying	Diesel	1	476.32 (litre)	458	1.04 (litre/ha)	165 (kwh)	50 (%)	15 (km/hr)	24 (m)	55 (%)
In Season	Spraying	Boom spraying	Diesel	2	476.32 (litre)	458	1.04 (litre/ha)	165 (kwh)	50 (%)	15 (km/hr)	24 (m)	55 (%)
In Season	Tillage	Inter-row Cultivating	Diesel	1	2294.58 (litre)	458	5.01 (litre/ha)	165 (kwh)	60 (%)	9.5 (km/hr)	8 (m)	65 (%)
In Season	Spraying	Airplane Spraying	Diesel	2	16.03 (litre)	458	0.035 (litre/ha)	-	-	-	-	-
In Season	Spraying	Airplane Spraying	Diesel	2	16.03 (litre)	458	0.035 (litre/ha)	-	-	-	-	-
Harvest	Harvesting	Cotton Picker	Diesel	1	20610.00 (litre)	458	45 (litre/ha)	-	-	-	-	-
Harvest	Infield transport	Infield Trailer	Diesel	1	1374.00 (litre)	458	3 (litre/ha)	-	-	-	-	-
Harvest	Infield transport	Module Builder	Diesel	2	1433.54 (litre)	458	3.13 (litre/ha)	60 (kwh)	50 (%)	8 (km/hr)	4 (m)	75 (%)
Post Harvest	Crop Destruction	Alloway Stubble Buster	Diesel	1	3572.40 (litre)	458	7.80 (litre/ha)	185 (kwh)	85 (%)	9 (km/hr)	8 (m)	70 (%)
Post Harvest	Crop Destruction	Root Cut	Diesel	1	984.70 (litre)	458	2.15 (litre/ha)	165 (kwh)	50 (%)	15 (km/hr)	8 (m)	80 (%)
Post Harvest	Crop Destruction	Ripper (Pupae Bust)	Diesel	1	5225.78 (litre)	458	11.41 (litre/ha)	211 (kwh)	90 (%)	8 (km/hr)	8 (m)	65 (%)

Table 6 - MACHINERY - PUMP ENERGY INPUTS

Process	Operation Type	Machinery	Energy source (cost)	No. of Operation	Energy use per operation	Area (ha)	Water used per ha	Energy Source per ML water	Energy used per hr	Flowrate	Head pressure	Pump efficiency	Hrs per shift	Area per shift	Energy used per hour	Water per ha
Irrigation	Water Supply & Distribution	Relift	Electricity	1	1624755.00 (kwh)	458	2.5 (ml/ha)	1419 (kwh/ml)	-	-	-	-	-	-	-	-
Irrigation	Water Supply & Distribution	Relift	Electricity	1	378917.14 (kwh)	458	2.23 (ml/ha)	371 (kwh/ml)	-	-	-	-	-	-	-	-

Irrigated - Cotton - 458 ha

Table 7 - SUMMARY OF ENERGY USE

Machinery	Energy Source	Annual / seasonal consumption	Standard Energy (GJ)		Emission (kg)		Cost (A\$)	
			GJ	%	kg	%	\$	%
Alloway Stubble Bust	Diesel	3572.4 (litre)	137.89	1	10359.96	0	4215.43	1
Discing	Diesel	10085.16 (litre)	389.29	4	29246.96	1	11900.49	4
Ripper	Diesel	6183 (litre)	238.66	2	17930.7	1	7295.94	3
Bedforming	Diesel	4277.72 (litre)	165.12	2	12405.39	1	5047.71	2
Boom spraying	Diesel	613.72 (litre)	23.69	0	1779.79	0	724.19	0
Fertiliser Bar	Diesel	3595.3 (litre)	138.78	1	10426.37	0	4242.45	2
Direct Drilling	Diesel	2019.78 (litre)	77.96	1	5857.36	0	2383.34	1
Boom spraying	Diesel	476.32 (litre)	18.39	0	1381.33	0	562.06	0
Boom spraying	Diesel	952.64 (litre)	36.77	0	2762.66	0	1124.12	0
Inter-row Cultivating	Diesel	2294.58 (litre)	88.57	1	6654.28	0	2707.6	1
Airplane Spraying	Diesel	32.06 (litre)	1.24	0	92.97	0	37.83	0
Airplane Spraying	Diesel	32.06 (litre)	1.24	0	92.97	0	37.83	0
Relift	Electricity	1624755 (kwh)	5849.12	59	1699493.73	74	162475.5	58
Relift	Electricity	378917.14 (kwh)	1364.1	14	396347.33	17	37891.71	13
Cotton Picker	Diesel	20610 (litre)	795.55	8	59769	3	24319.8	9
Infield Trailer	Diesel	1374 (litre)	53.04	1	3984.6	0	1621.32	1
Module Builder	Diesel	2867.08 (litre)	110.67	1	8314.53	0	3383.15	1
Alloway Stubble Buster	Diesel	3572.4 (litre)	137.89	1	10359.96	0	4215.43	1
Root Cut	Diesel	984.7 (litre)	38.01	0	2855.63	0	1161.95	0
Ripper (Pupae Bust)	Diesel	5225.78 (litre)	201.72	2	15154.76	1	6166.42	2
Total	-	-	9867.7	100	2295270.28	100	281514.28	100

Irrigated - Cotton - 458 ha

Table 8 - PERFORMANCE INDICATORS

Application of Energy (Processes)	Energy consumed (GJ)		Energy Intensity parameter	Energy intensity (GJ per ...)		Greenhouse gas emission intensity (kg CO ₂ per ...)		Energy cost intensity (\$ per ...)	
	Current	%		Current	Benchmark	Current	Benchmark	Current	Benchmark
Preparation	1093.43	11	per hectare	0.96		72.06		29.32	
			per yield	0.16		12.01		4.89	
Establishment	96.35	1	per hectare	0.08		6.35		2.58	
			per yield	0.01		1.06		0.43	
In Season	127.82	1	per hectare	0.11		8.42		3.43	
			per yield	0.02		1.4		0.57	
Irrigation	7213.22	73	per hectare	6.33		1838.46		175.76	
			per yield	1.05		306.36		29.29	
Harvest	959.26	10	per hectare	0.84		63.22		25.72	
			per yield	0.14		10.53		4.29	
Post Harvest	377.62	4	per hectare	0.33		24.89		10.13	
			per yield	0.06		4.15		1.69	
Total	9867.7	100	per hectare	8.66		2013.39		246.94	
			per yield	1.44		335.52		41.15	

Irrigated - Wheat - 284 ha

Table 10 - MACHINERY - TRACTOR ENERGY INPUTS

Process	Operation Type	Machinery	Energy source (cost)	No. of Operation	Energy use per operation	Area (ha)	Energy source per area	Engine power	Engine load	Ground speed	Working width	Work rate
Preparation	Fertilising	Bed Renovator	Diesel	1	3240.44 (litre)	284	11.41 (litre/ha)	211 (kwh)	90 (%)	8 (km/hr)	8 (m)	65 (%)
Preparation	Tillage	Rolling	Diesel	1	494.16 (litre)	284	1.74 (litre/ha)	89 (kwh)	50 (%)	10 (km/hr)	8 (m)	80 (%)
Establishment	Planting	Airseeder	Diesel	1	1965.28 (litre)	284	6.92 (litre/ha)	185 (kwh)	70 (%)	9 (km/hr)	8 (m)	65 (%)
Establishment	Spraying	Boom spraying	Diesel	1	204.48 (litre)	284	0.72 (litre/ha)	165 (kwh)	50 (%)	15 (km/hr)	24 (m)	80 (%)
Establishment	Spraying	Boom Spray (fertiliser)	Diesel	1	204.48 (litre)	284	0.72 (litre/ha)	165 (kwh)	50 (%)	15 (km/hr)	24 (m)	80 (%)
Harvest	Harvesting	Combine Harvester	Diesel	1	3444.92 (litre)	284	12.13 (litre/ha)	160 (kwh)	90 (%)	7 (km/hr)	8 (m)	53 (%)
Post Harvest	Crop Destruction	Boom Spraying	Diesel	1	204.48 (litre)	284	0.72 (litre/ha)	165 (kwh)	50 (%)	15 (km/hr)	24 (m)	80 (%)

Table 11 - MACHINERY - PUMP ENERGY INPUTS

Process	Operation Type	Machinery	Energy source (cost)	No. of Operation	Energy use per operation	Area (ha)	Water used per ha	Energy Source per ML water	Energy used per hr	Flowrate	Head pressure	Pump efficiency	Hrs per shift	Area per shift	Energy used per hour	Water per ha
Irrigation	Water Supply & Distribution	Relift	Electricity	1	691741.64 (kwh)	284	2.27 (ml/ha)	1073 (kwh/ml)	-	-	-	-	-	-	-	-
Irrigation	Water Supply & Distribution	Relift	Electricity	1	152167.20 (kwh)	284	2.28 (ml/ha)	235 (kwh/ml)	-	-	-	-	-	-	-	-

Irrigated - Wheat - 284 ha

Table 12 - SUMMARY OF ENERGY USE

Machinery	Energy Source	Annual / seasonal consumption	Standard Energy (GJ)		Emission (kg)		Cost (A\$)	
			GJ	%	kg	%	\$	%
Bed Renovator	Diesel	3240.44 (litre)	125.08	4	9397.28	1	3823.72	4
Rolling	Diesel	494.16 (litre)	19.07	1	1433.06	0	583.11	1
Airseeder	Diesel	1965.28 (litre)	75.86	2	5699.31	1	2319.03	2
Boom spraying	Diesel	204.48 (litre)	7.89	0	592.99	0	241.29	0
Boom Spray (fertiliser)	Diesel	204.48 (litre)	7.89	0	592.99	0	241.29	0
Relift	Electricity	691741.64 (kwh)	2490.27	73	723561.76	79	69174.16	72
Relift	Electricity	152167.2 (kwh)	547.8	16	159166.89	17	15216.72	16
Combine Harvester	Diesel	3444.92 (litre)	132.97	4	9990.27	1	4065.01	4
Boom Spraying	Diesel	204.48 (litre)	7.89	0	592.99	0	241.29	0
Total	-	-	3414.72	100	911027.54	100	95905.61	100

Irrigated - Wheat - 284 ha

Table 13 - PERFORMANCE INDICATORS

Application of Energy (Processes)	Energy consumed (GJ)		Energy Intensity parameter	Energy intensity (GJ per ...)		Greenhouse gas emission intensity (kg CO2 per ...)		Energy cost intensity (\$ per ...)	
	Current	%		Current	Benchmark	Current	Benchmark	Current	Benchmark
Preparation	144.15	4	per hectare	0.13		9.5		3.87	
Establishment	91.64	3	per hectare	0.02		1.58		0.64	
Irrigation	3038.07	89	per yield	0.08		6.04		2.46	
Harvest	132.97	4	per hectare	0.01		1.01		0.41	
Post Harvest	7.89	0	per hectare	2.66		774.32		74.03	
			per yield	0.44		129.04		12.34	
			per hectare	0.12		8.76		3.57	
			per yield	0.02		1.46		0.59	
			per hectare	0.01		0.52		0.21	
			per yield	0		0.09		0.04	
Total	3414.72	100	per hectare	3		799.15		84.13	
			per yield	0.5		133.17		14.02	

Dryland - Sorghum - 84 ha

Table 15 - MACHINERY - TRACTOR ENERGY INPUTS

Process	Operation Type	Machinery	Energy source (cost)	No. of Operation	Energy use per operation	Area (ha)	Energy source per area	Engine power	Engine load	Ground speed	Working width	Work rate
Preparation	Spraying	Boom spraying	Diesel	3	63.84 (litre)	84	0.76 (litre/ha)	165 (kwh)	50 (%)	15 (km/hr)	24 (m)	75 (%)
Establishment	Planting	Direct Drilling	Diesel	1	370.44 (litre)	84	4.41 (litre/ha)	165 (kwh)	50 (%)	9 (km/hr)	8 (m)	65 (%)
In Season	Spraying	Boom spraying	Diesel	1	63.84 (litre)	84	0.76 (litre/ha)	165 (kwh)	50 (%)	15 (km/hr)	24 (m)	75 (%)
In Season	Spraying	Airplane Spraying	Diesel	1	2.94 (litre)	84	0.035 (litre/ha)	-	-	-	-	-
In Season	Spraying	Airplane Spraying	Diesel	1	2.94 (litre)	84	0.035 (litre/ha)	-	-	-	-	-
Harvest	Harvesting	Combine Harvester	Diesel	1	1018.92 (litre)	84	12.13 (litre/ha)	160 (kwh)	90 (%)	7 (km/hr)	8 (m)	53 (%)

Dryland - Sorghum - 84 ha

Table 16 - SUMMARY OF ENERGY USE

Machinery	Energy Source	Annual / seasonal consumption	Standard Energy (GJ)		Emission (kg)		Cost (A\$)	
			GJ	%	kg	%	\$	%
Boom spraying	Diesel	191.52 (litre)	7.39	12	555.41	12	225.99	12
Direct Drilling	Diesel	370.44 (litre)	14.3	22	1074.28	22	437.12	22
Boom spraying	Diesel	63.84 (litre)	2.46	4	185.14	4	75.33	4
Airplane Spraying	Diesel	2.94 (litre)	0.11	0	8.53	0	3.47	0
Airplane Spraying	Diesel	2.94 (litre)	0.11	0	8.53	0	3.47	0
Combine Harvester	Diesel	1018.92 (litre)	39.33	62	2954.87	62	1202.33	62
Total	-	-	63.7	100	4786.76	100	1947.71	100

Dryland - Sorghum - 84 ha

Table 17 - PERFORMANCE INDICATORS

Application of Energy (Processes)	Energy consumed (GJ)		Energy Intensity parameter	Energy intensity (GJ per ...)		Greenhouse gas emission intensity (kg CO2 per ...)		Energy cost intensity (\$ per ...)	
	Current	%		Current	Benchmark	Current	Benchmark	Current	Benchmark
Preparation	7.39	12	per hectare	0.01		0.49		0.2	
			per yield	0		0.08		0.03	
Establishment	14.3	22	per hectare	0.01		0.94		0.38	
			per yield	0		0.16		0.06	
In Season	2.68	4	per hectare	0		0.18		0.07	
			per yield	0		0.03		0.01	
Harvest	39.33	62	per hectare	0.03		2.59		1.05	
			per yield	0.01		0.43		0.18	
Total	63.7	100	per hectare	0.06		4.2		1.71	
			per yield	0.01		0.7		0.28	

Dryland - Pigeon Pea - 29 ha

Table 19 - MACHINERY - TRACTOR ENERGY INPUTS

Process	Operation Type	Machinery	Energy source (cost)	No. of Operation	Energy use per operation	Area (ha)	Energy source per area	Engine power	Engine load	Ground speed	Working width	Work rate
Preparation	Spraying	Boom spraying	Diesel	1	30.16 (litre)	29	1.04 (litre/ha)	165 (kwh)	50 (%)	15 (km/hr)	24 (m)	55 (%)
Preparation	Fertilising	Bedforming + MAP	Diesel	1	227.65 (litre)	29	7.85 (litre/ha)	185 (kwh)	75 (%)	8.5 (km/hr)	8 (m)	65 (%)
Establishment	Planting	Direct Drilling	Diesel	1	127.89 (litre)	29	4.41 (litre/ha)	165 (kwh)	50 (%)	9 (km/hr)	8 (m)	65 (%)
In Season	Spraying	Shielded Spray	Diesel	1	151.09 (litre)	29	5.21 (litre/ha)	165 (kwh)	50 (%)	9 (km/hr)	8 (m)	55 (%)
In Season	Tillage	Inter-row Cultivating	Diesel	1	145.29 (litre)	29	5.01 (litre/ha)	165 (kwh)	60 (%)	9.5 (km/hr)	8 (m)	65 (%)
Harvest	Harvesting	Combine Harvester	Diesel	1	351.77 (litre)	29	12.13 (litre/ha)	160 (kwh)	90 (%)	7 (km/hr)	8 (m)	53 (%)
Post Harvest	Crop Destruction	Alloway Stubble Buster	Diesel	1	226.20 (litre)	29	7.80 (litre/ha)	185 (kwh)	85 (%)	9 (km/hr)	8 (m)	70 (%)
Post Harvest	Crop Destruction	Root Cut	Diesel	1	58.58 (litre)	29	2.02 (litre/ha)	165 (kwh)	50 (%)	15 (km/hr)	8 (m)	85 (%)
Post Harvest	Crop Destruction	Ripper (Pupae Bust)	Diesel	1	330.89 (litre)	29	11.41 (litre/ha)	211 (kwh)	90 (%)	8 (km/hr)	8 (m)	65 (%)

Dryland - Pigeon Pea - 29 ha

Table 20 - SUMMARY OF ENERGY USE

Machinery	Energy Source	Annual / seasonal consumption	Standard Energy (GJ)		Emission (kg)		Cost (AS)	
			GJ	%	kg	%	\$	%
Boom spraying	Diesel	30.16 (litre)	1.16	2	87.46	2	35.59	2
Bedforming + MAP	Diesel	227.65 (litre)	8.79	14	660.18	14	268.63	14
Direct Drilling	Diesel	127.89 (litre)	4.94	8	370.88	8	150.91	8
Shielded Spray	Diesel	151.09 (litre)	5.83	9	438.16	9	178.29	9
Inter-row Cultivating	Diesel	145.29 (litre)	5.61	9	421.34	9	171.44	9
Combine Harvester	Diesel	351.77 (litre)	13.58	21	1020.13	21	415.09	21
Alloway Stubble Buster	Diesel	226.2 (litre)	8.73	14	655.98	14	266.92	14
Root Cut	Diesel	58.58 (litre)	2.26	4	169.88	4	69.12	4
Ripper (Pupae Bust)	Diesel	330.89 (litre)	12.77	20	959.58	20	390.45	20
Total	-	-	63.67	100	4783.59	100	1946.43	100

Dryland - Pigeon Pea - 29 ha

Table 21 - PERFORMANCE INDICATORS

Application of Energy (Processes)	Energy consumed (GJ)		Energy Intensity parameter	Energy intensity (GJ per ...)		Greenhouse gas emission intensity (kg CO ₂ per ...)		Energy cost intensity (\$ per ...)	
	Current	%		Current	Benchmark	Current	Benchmark	Current	Benchmark
Preparation	9.95	16	per hectare	0.01		0.66		0.27	
Establishment	4.94	8	per yield	0		0.11		0.04	
			per hectare	0		0.33		0.13	
In Season	11.44	18	per yield	0		0.05		0.02	
			per hectare	0.01		0.75		0.31	
Harvest	13.58	21	per yield	0		0.13		0.05	
			per hectare	0.01		0.89		0.36	
Post Harvest	23.76	37	per yield	0		0.15		0.06	
			per hectare	0.02		1.57		0.64	
Total	63.67	100	per yield	0		0.26		0.11	
			per hectare	0.06		4.2		1.71	
			per yield	0.01		0.7		0.28	

Dryland - Wheat - 94 ha

Table 23 - MACHINERY - TRACTOR ENERGY INPUTS

Process	Operation Type	Machinery	Energy source (cost)	No. of Operation	Energy use per operation	Area (ha)	Energy source per area	Engine power	Engine load	Ground speed	Working width	Work rate
Preparation	Spraying	Boom spraying	Diesel	7	71.44 (litre)	94	0.76 (litre/ha)	165 (kwh)	50 (%)	15 (km/hr)	24 (m)	75 (%)
Establishment	Planting	Direct Drilling	Diesel	1	650.48 (litre)	94	6.92 (litre/ha)	185 (kwh)	70 (%)	9 (km/hr)	8 (m)	65 (%)
In Season	Spraying	Boom spraying	Diesel	1	71.44 (litre)	94	0.76 (litre/ha)	165 (kwh)	50 (%)	15 (km/hr)	24 (m)	75 (%)
In Season	Fertilising	Easy N Application	Diesel	1	71.44 (litre)	94	0.76 (litre/ha)	165 (kwh)	50 (%)	15 (km/hr)	24 (m)	75 (%)
In Season	Spraying	Boom Spray (fungicide)	Diesel	1	71.44 (litre)	94	0.76 (litre/ha)	165 (kwh)	50 (%)	15 (km/hr)	24 (m)	75 (%)
Harvest	Harvesting	Combine Harvester	Diesel	1	1098.86 (litre)	94	11.69 (litre/ha)	160 (kwh)	90 (%)	7 (km/hr)	8 (m)	55 (%)

Dryland - Wheat - 94 ha

Table 24 - SUMMARY OF ENERGY USE

Machinery	Energy Source	Annual / seasonal consumption	Standard Energy (GJ)		Emission (kg)		Cost (A\$)	
			GJ	%	kg	%	\$	%
Boom spraying	Diesel	500.08 (litre)	19.3	20	1450.23	20	590.09	20
Direct Drilling	Diesel	650.48 (litre)	25.11	26	1886.39	26	767.57	26
Boom spraying	Diesel	71.44 (litre)	2.76	3	207.18	3	84.3	3
Easy N Application	Diesel	71.44 (litre)	2.76	3	207.18	3	84.3	3
Boom Spray (fungicide)	Diesel	71.44 (litre)	2.76	3	207.18	3	84.3	3
Combine Harvester	Diesel	1098.86 (litre)	42.42	45	3186.69	45	1296.65	45
Total	-	-	95.11	100	7144.85	100	2907.21	100

Dryland - Wheat - 94 ha

Table 25 - PERFORMANCE INDICATORS

Application of Energy (Processes)	Energy consumed (GJ)		Energy Intensity parameter	Energy intensity (GJ per ...)		Greenhouse gas emission intensity (kg CO2 per ...)		Energy cost intensity (\$ per ...)	
	Current	%		Current	Benchmark	Current	Benchmark	Current	Benchmark
Preparation	19.3	20	per hectare	0.02		1.27		0.52	
Establishment	25.11	26	per hectare	0		0.21		0.09	
In Season	8.28	9	per hectare	0.02		1.65		0.67	
Harvest	42.42	45	per yield	0		0.28		0.11	
			per hectare	0.01		0.55		0.22	
			per yield	0		0.09		0.04	
			per hectare	0.04		2.8		1.14	
			per yield	0.01		0.47		0.19	
Total	95.11	100	per hectare	0.08		6.27		2.55	
			per yield	0.01		1.04		0.42	

Dryland with one irrigation - Cotton - 191 ha

Table 27 - MACHINERY - TRACTOR ENERGY INPUTS

Process	Operation Type	Machinery	Energy source (cost)	No. of Operation	Energy use per operation	Area (ha)	Energy source per area	Engine power	Engine load	Ground speed	Working width	Work rate
Preparation	Fertilising	Bedforming + MAP	Diesel	1	1499.35 (litre)	191	7.85 (litre/ha)	185 (kwh)	75 (%)	8.5 (km/hr)	8 (m)	65 (%)
Preparation	Spraying	Boom spraying	Diesel	2	127.97 (litre)	191	0.67 (litre/ha)	165 (kwh)	50 (%)	15 (km/hr)	24 (m)	85 (%)
Establishment	Planting	Direct Drilling	Diesel	1	748.72 (litre)	191	3.92 (litre/ha)	165 (kwh)	50 (%)	9 (km/hr)	9 (m)	65 (%)
Establishment	Planting	Boom Spray	Diesel	1	198.64 (litre)	191	1.04 (litre/ha)	165 (kwh)	50 (%)	15 (km/hr)	24 (m)	55 (%)
In Season	Spraying	Boom Spray RR	Diesel	1	198.64 (litre)	191	1.04 (litre/ha)	165 (kwh)	50 (%)	15 (km/hr)	24 (m)	55 (%)
In Season	Tillage	Inter-row Cultivating	Diesel	1	956.91 (litre)	191	5.01 (litre/ha)	165 (kwh)	60 (%)	9.5 (km/hr)	8 (m)	65 (%)
In Season	Spraying	Aerial (defoliation)	Diesel	2	6.69 (litre)	191	0.035 (litre/ha)	-	-	-	-	-
In Season	Spraying	Aerial (Insecticide)	Diesel	1	6.69 (litre)	191	0.035 (litre/ha)	-	-	-	-	-
Harvest	Harvesting	Cotton Picker	Diesel	1	8595.00 (litre)	191	45 (litre/ha)	-	-	-	-	-
Harvest	Infield transport	Infield Trailer	Diesel	1	573.00 (litre)	191	3 (litre/ha)	-	-	-	-	-
Harvest	Harvesting	Module Builder	Diesel	1	597.83 (litre)	191	3.13 (litre/ha)	-	-	-	-	-
Post Harvest	Crop Destruction	Alloway Stubble Buster	Diesel	1	1489.80 (litre)	191	7.80 (litre/ha)	185 (kwh)	85 (%)	9 (km/hr)	8 (m)	70 (%)
Post Harvest	Crop Destruction	Root Cut	Diesel	1	410.65 (litre)	191	2.15 (litre/ha)	165 (kwh)	50 (%)	15 (km/hr)	8 (m)	80 (%)
Post Harvest	Crop Destruction	Ripper (Pupae Bust)	Diesel	1	2179.31 (litre)	191	11.41 (litre/ha)	211 (kwh)	90 (%)	8 (km/hr)	8 (m)	65 (%)

Dryland with one irrigation - Cotton - 191 ha

Table 28 - SUMMARY OF ENERGY USE

Machinery	Energy Source	Annual / seasonal consumption	Standard Energy (GJ)		Emission (kg)		Cost (A\$)	
			GJ	%	kg	%	\$	%
Bedforming + MAP	Diesel	1499.35 (litre)	57.87	8	4348.11	8	1769.23	8
Boom spraying	Diesel	255.94 (litre)	9.88	1	742.23	1	302.01	1
Direct Drilling	Diesel	748.72 (litre)	28.9	4	2171.29	4	883.49	4
Boom Spray	Diesel	198.64 (litre)	7.67	1	576.06	1	234.4	1
Boom Spray RR	Diesel	198.64 (litre)	7.67	1	576.06	1	234.4	1
Inter-row Cultivating	Diesel	956.91 (litre)	36.94	5	2775.04	5	1129.15	5
Aerial (defoliation)	Diesel	13.38 (litre)	0.52	0	38.8	0	15.79	0
Aerial (Insecticide)	Diesel	6.69 (litre)	0.26	0	19.4	0	7.89	0
Cotton Picker	Diesel	8595 (litre)	331.77	48	24925.5	48	10142.1	48
Infield Trailer	Diesel	573 (litre)	22.12	3	1661.7	3	676.14	3
Module Builder	Diesel	597.83 (litre)	23.08	3	1733.71	3	705.44	3
Alloway Stubble Buster	Diesel	1489.8 (litre)	57.51	8	4320.42	8	1757.96	8
Root Cut	Diesel	410.65 (litre)	15.85	2	1190.88	2	484.57	2
Ripper (Pupae Bust)	Diesel	2179.31 (litre)	84.12	12	6320	12	2571.59	12
Total	-	-	684.16	100	51399.2	100	20914.15	100

Dryland with one irrigation - Cotton - 191 ha

Table 29 - PERFORMANCE INDICATORS

Application of Energy (Processes)	Energy consumed (GJ)		Energy Intensity parameter	Energy intensity (GJ per ...)		Greenhouse gas emission intensity (kg CO2 per ...)		Energy cost intensity (\$ per ...)	
	Current	%		Current	Benchmark	Current	Benchmark	Current	Benchmark
Preparation	67.75	10	per hectare	0.06		4.47		1.82	
			per yield	0.01		0.74		0.3	
Establishment	36.57	5	per hectare	0.03		2.41		0.98	
			per yield	0.01		0.4		0.16	
In Season	45.39	7	per hectare	0.04		2.99		1.22	
			per yield	0.01		0.5		0.2	
Harvest	376.97	55	per hectare	0.33		24.84		10.11	
			per yield	0.06		4.14		1.68	
Post Harvest	157.48	23	per hectare	0.14		10.38		4.22	
			per yield	0.02		1.73		0.7	
Total	684.16	100	per hectare	0.6		45.09		18.35	
			per yield	0.1		7.51		3.06	

Appendix F: Tractor monitoring and the ISOBUS standard

Tractor monitoring and the ISOBUS standard

The ECU and diesel injection and measurement

All modern diesel engines are controlled by an ECU, or an Electronic Control Unit. The ECU is essentially a computer that controls engine function, particularly when and how much diesel is injected into each cylinder. The ECU monitors various engine sensors, such as load, speed and exhaust gas composition. The ECU calculates diesel injection volume and timing by cross-referencing these values against a pre-determined 'performance map'. Once the ECU has determined that diesel is to be injected into a particular cylinder it sends an electrical pulse to the injector. This pulse is used to lift a needle valve away from a very small venturi. Diesel, which is continuously supplied to the injector at very high pressure, is now free to pass through this venturi in a predictable manner. This method is known as 'common rail fuel injection' and is used on all modern diesel engines. Diesel use is measured by accumulating the lift time of each injector (as determined by the ECU) and by knowing how fast diesel will flow through the venturi during this time. With injection volumes in the order of 0.03 ml per needle lift it may be surprising to know that at a tractor fuel burn rate of say 32 litres per hour is measured at around 0.03 ml at a time. This method is, in fact, a very accurate method of measuring fuel use because the lift time is known and controlled very precisely by the ECU.

Tractor monitoring and the ISOBUS standard

The ISOBUS standard (ISO 11783: Tractors and machinery for Agriculture and Forestry — Serial Control and Communications Data Network standard) is in short, a common communication platform that should allow sensor developed by any manufacturer to communicate with sensors developed by any other manufacturer. This large and comprehensive standard includes protocols for information exchange between sensors, ECU communication protocols, GPS protocols and more.

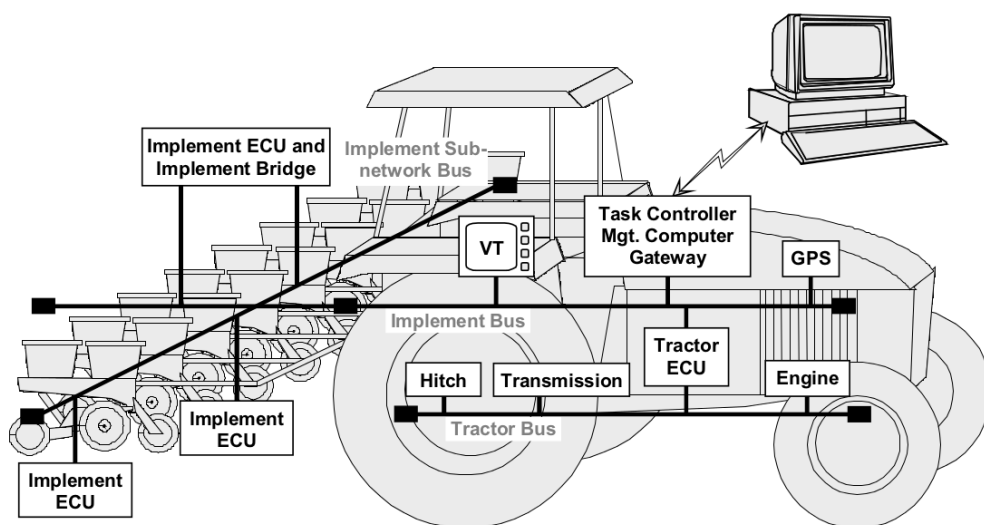

Figure 1: The ISOBUS system for a typical tractor - implement system.

Tractor ECU (TECU) standards under the ISOBUS standard

The TECU is an ECU which acts as a gateway between the tractor and the implement and converts and processes data and tractor bus messages for the implement. There are three classes of tractor ECUs: Class 1 to 3 and they define what access and control of the TECU is allowable by any ECU on the implement bus. Class 1 TECUs are not recommended for new tractors but are used for tractors built without ISOBUS but later fitted the standard system. Class 2 TECUs have full access to available information and Class 3 TECUs are for tractors towing implements which control their own depth, power and hydraulic force demands.

ISOBUS and manufacturer acceptance

European tractor manufacturers have long had an acceptance of the ISOBUS standard. John Deere has a major commitment to the ISO 11783 standard (pers. Com., Walsh, 2012) and CNH may have an equal or less commitment. Walsh (2012) estimated half of John Deere's 8x20 series tractors and larger are ISO 11783 compatible (made in 2002–2005 and are 170 horse power (hp) and greater) and all of their 7x30 (2007 models, 100 hp and greater) are compatible. It is interesting to note that they now appear to be producing all new tractors greater than about 160 hp with the ISO 11783 standard.

It is not clear to what extent ISO 11783 is adopted on CNH machinery. Gharzeei-Khabbaz (Pers. Comm. 2012) states that their tractors only provide level one information or some of level two information. Since a tractor ECU class must provide the minimum information, this would mean their tractors are mainly class one (see Figure 1 which shows the standard information available to the ISO 11783 system where level would mean class). Self-propelled machines like the cane harvester are not stated as sharing information.

ISO 11783 for Research Purposes

Some researchers have expressed that the ISOBUS standard provides convenience. Benneweis (2005) says the ISO 11783 offers an excellent opportunity for researchers in agriculture since the virtual terminal can offer new tasks without changes to software or hardware. Pereira (2011) created a work bench for remote use by researchers to learn about ISO 11783. They say the IsoAgLib, a library of C++ functions and programs, can be used to allow a personal computer to act like an ECU. All it takes is connector (or a Hardware Abstraction Layer) to connect a laptop to an ISO 11783 compliant tractor to begin communicating with ECUs. It is not known yet how much this would cost or how useful this would be.

References and further reading

Auerhammer, H., & Speckman, H. (2006). Dedicated communication systems and standards for agricultural applications *Section 7.1 Communication issues and internet use - ASAE CIGR Handbook of Agricultural Engineering* (pp. 435--452).

Benneweis, R. K. (2005). *Status of the ISO 11783 serial control and communications data network standard*.

Deere and Company (2012) *2630 GreenStar Display*. Smart hardware system. Deere and Company, Moline, Illinois:.

Deere and Company (2012) *APEX Farm Management Software*, Software. Deere and Company, Moline, Illinois:

- Embedded System. (2012) Retrieved 6 June 2012, from <http://encyclopedia.thefreedictionary.com/embedded+system>
- Gharzeei-Khabbaz, B. (June 2012). Pers. Comm.
- Isermann, R. (1999). 2.2 Sensors *CIGR handbook of agricultural engineering, Volume 6: Information Technology*.
- ISO/DIN 11783 - 14: Tractors and machinery for agriculture and forestry - Serial control and communications data network - Part 1: General standard for mobile data communication. (2007). Geneva.
- ISO/DIN 11783 - 14: Tractors and machinery for agriculture and forestry - Serial control and communications data network - Part 9: Tractor ECU. (2002). Geneva.
- ISO/DIN 11783 - 14: Tractors and machinery for agriculture and forestry - Serial control and communications data network - Part 14: Sequence control. Retrieved 6 June 2012, from www.saiglobal.com
- Markworth, N. (2006). Sampling Theory, from www.physics.sfasu.edu/markworth/phy110/Sampling.ppt
- Navet, N., & Simonot-Lion, F. (2009). *Automotive Embedded Systems Handbook*: CRC Press.
- Pereira, R. R. D. L., W. C. Sousa, R. V. Porto, A. J. V. & Inamasu, R. Y. (2011). *Object oriented C++ library IsoAgLib study and implementation from the remote CAN-Based Distributed Control System*.
- Srivastava, A. K., Goering, R. P., Rohrbach, R. P., Buckmaster, D. R. (2006). Precision agriculture *Engineering Principles of Agricultural Machines* (2 nd ed., pp. 123--138). St. Joseph, Michigan: ASABE.
- Stone, M. L., Benneweis, R. K., & Van Bergeijk, J. (2008). Evolution of electronics for mobile agricultural equipment. *Transactions of the ASABE*, 51(2), 385-390.
- Voss, W. (2008). *SAE J1939: serial control and communications vehicle network*. Greenfield: ESD Electronics Inc.
- Walsh, P. (June 2012). Pers. Comm.

Appendix G: Promoting Energy Assessment and Reporting Tools

The following promotional and extension activities occurred during the project. Extension activities will be on-going and the results of this work will be persistent.

2010

- Paper presentation at 2010 Australian Cotton Conference to generate awareness of energy work and NEC 1011. Managing Direct Energy Use - Now and in the Future Baillie and Pyke (2010)
- CSD webcast: CSD produced a webcast promoting previous and future energy work and key messages. The webcast was based on a conference presentation at the 2010 Australian Cotton Conference. The link to the CSD webcast presentation is <http://www.csd.net.au/wow/show/1492>.
- Attended RIRDC facilitated workshop on Life Cycle Assessment (LCA) R&D to connect current energy work with related initiatives. The workshop included discussion on the development of a Life Cycle Inventory (LCI) to support rural LCA.

2011

- Media articles prepared for Irrigation Australia journal and CRDC spotlight magazine
- Cotton Production Manual: A chapter was developed for the cotton production guide prior to the 2010 Australian Cotton Conference. This chapter was revised in April 2011.
- Irrigation Australia Limited (IAL) journal article: A general media article was written to promote the current project activities and to highlight the importance of irrigation in on-farm energy use.
- CRDC Spotlight Magazine article: A similar article to the IAL journal was written to promote energy work and to highlight key considerations for energy use and reduction.
- Presentation to North West NSW IAL Branch: An information seminar organised by the North West NSW branch of IAL was held on 5 August 2011 in Narrabri. The theme of the information seminar was reducing pumping costs and optimising energy efficiency. In particular the concept of energy assessments and reporting tools were promoted highlighting the significance of irrigation in terms of total on-farm energy use and greenhouse gas emissions. Other topics included pump efficiency, energy costs, diesel / gas engine conversions, bore pump maintenance and variable speed drive technologies which included speakers from NSW Office of Water, NSW Primary Industries and specialists in various pump technologies
- Presentation at the Cotton Collective Cotton Industry Forum: A presentation was made at the Cotton Collective Industry Forum organised by Cotton Australia on 10 August 2011 in Narrabri. The presentation contributed to a session involving 4 speakers on the Carbon Tax & the Carbon Farming Initiative. The presentation entitled *Managing Energy Use in Cotton Production* outlined the significance of direct energy use on-farm, the importance due to rising energy costs and the significance in terms of greenhouse gas emissions. The presentation also outlined other energy work undertaken by NCEA including energy and cotton ginning work and current postgraduate initiatives aligned with CRDC funded activities. Energy assessments and energy efficiency was promoted as a proactive opportunity for the cotton industry to reduce production costs while significantly reducing the total carbon footprint.

- Paper presented at the SEAg conference: A conference paper was presented at the 2011 CIGR International Symposium of the Australian Society for Engineering in Agriculture “Engineering in Agriculture – Diverse Challenges, Innovative Solutions”, 29 and 30 September on the Gold Coast. This presentation provided an overview of energy assessment work undertaken in the cotton industry, the assessment process which has been developed and the outcomes of this work with particular focus on the significance of irrigation. The conference paper and presentation was an opportunity for peer review by an international audience.
- Presentation to Darling Downs IAL Branch: A presentation was made at the Darling Downs IAL Branch meeting on 27 October which had a particular focus on energy use in irrigation. The presentation highlighted irrigation energy requirements and the assessment tools and processes that have been developed by the NCEA through the current project to assist irrigation service providers.

2012

- Gwydir Valley Irrigators Association (GVIA) Field Day end January 2012. In January a presentation was given to the Gwydir Valley Irrigators Field day outlining the energy assessment process and project activities undertaken by this project (NEC1101). The presentation also put into context the importance of irrigation in relation to whole farm energy use and resulting greenhouse gas emissions.
- A general media article has been written which provides an overview of the current energy funded initiatives including NEC1201 and NEC1101. This article has been prepared for Greenmount Press (i.e. Australian Cotton Grower) and will also target other popular rural press.
- An audio and video interview (for a web cast) was recorded with Stuart Bray from NSW DPI to promote both the project and current activities through the Cotton Industry Development and Delivery network.
- NSW DPI and QDAFF: Engagement with Janelle Montgomery and Lance Pendergast to integrate a broader assessment of on-farm energy and energy use from irrigation.
- A book chapter has been peer reviewed and accepted for publication and scheduled to be published in July 2012. Chen, G., Maraseni, T.N. (2012). "Agriculture: Energy Uses and Conservation ". In: Jorgensen, S.E (Editor). Encyclopaedia of Environmental Management, Taylor & Francis Books, London, UK.
- A paper was presented at the Australian Society of Sugarcane Technologist which outlined the current energy assessment processes developed in the cotton industry. Monitoring data obtained from previous studies in sugarcane was used to demonstrate the process and relevance to the sugar industry. The purpose of the presentation was to generate some awareness in sugar and to critique processes currently developed in the cotton industry for their applicability to other commodity crops.
- A general media article has been written for the CRDC Spotlight magazine. This magazine is widely disseminated to industry, as well as the scientific community and commercial parties and institutions. While the article provides an overview of current energy initiatives – NEC1201 and NEC 1101 – its focus is on specific issues and current happenings. The article particularly looks at what can be done right now to reduce energy consumption. The article explains pump efficiency and associated possible savings. It explains EnergyCalc and

EnergyCalc Lite can be used by a grower to identify savings and the benchmarking process behind the software. The article mentions the “Evaluation of Alternative Energy Resources for Cotton Production in Australia” report and some of its findings as well as different ideas for energy savings, such as fuel switching and electrical tariffs.

- Project researchers have contributed to:
 - a. The report “Evaluation of Alternative Energy Resources for Cotton Production in Australia” is available to industry, the scientific community, commercial parties and other institutions. It is a comprehensive report which examines the district-specific applicability of a wider range of alternative energies to the cotton industry.
 - b. Bundschuh, J., Chen, G. (book editors), Sustainable Energy Solutions in Agriculture, to be published by Taylor & Francis Books, UK in April 2014.
<http://www.crcpress.com/product/isbn/9781138001183>
 - c. Bundschuh, J., Chen, G. Mushtaq, S. (2014). "Towards a Sustainable Energy Technologies Based Agriculture". In Bundschuh, J. and Chen, G., (Editors). Sustainable Energy Solutions in Agriculture, Taylor & Francis Books, UK.
- The project has also contributed data and information to the RIRDC funded project *Developing a LCI database for Australian agriculture*, led by Sandra Eady, CSIRO.

2013

- Chen, G., Baillie, C, Eady, S., Grant, T. (2013), “Developing Life Cycle Inventory for Life Cycle Assessment of Australian Cotton”, Australian Life Cycle Assessment Conference, 14-18 July 2013, Sydney.