

1.8 Pumps

Peter Smith
NSW Department of Primary Industries

Lance Pendergast
DAFF Queensland

Key points

- Pumps are designed to operate within a range of duty points (flow and head)
- Pump curves contain information that is vital for pump selection or evaluation
- It is possible to measure pump characteristics and determine pumping costs
- Pumping costs can be monitored as an indicator of pump wear/failure
- Pump selection is very important – choosing the wrong pump may compromise the operation of the whole irrigation system
- Evaluating pump system efficiency provides information that can significantly reduce operating costs.

Introduction

A poorly performing pump may affect the entire irrigation system, reducing irrigation efficiency and productivity. For example, if a lateral move requires a specific flow rate and pressure but the pump is performing poorly, the flow rate and pressure may not be adequate to operate the sprinklers correctly. The result may be insufficient water applied and uneven distribution, reducing yield and increasing paddock variation.

This chapter contains information about:

- pump types;
- pump duty;
- pump curves;
- pump efficiency and energy use; and
- pump selection.

Common types of irrigation pumps

The main types of pump used for irrigation are:

- Radial flow ('centrifugal') pumps
- Mixed flow pumps
- Turbine pumps.

Radial flow ('centrifugal') pumps

Radial flow pumps are commonly referred to as 'centrifugal' pumps. (This may cause confusion, as mixed flow, electro-submersible, most sump and packaged pressure systems are also types of centrifugal pump.)

Radial flow impeller – high head – low flow

Liquid enters the impeller axially and is discharged radially. This changes the direction of water by 90 degrees.

The head developed is due to the centrifugal force exerted on the fluid by the impeller.

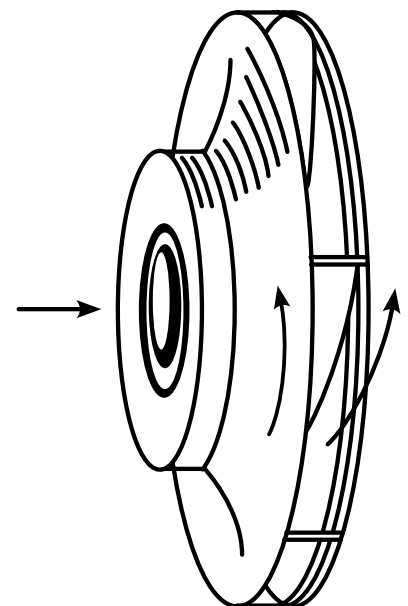

Mixed flow volute pumps

Where large quantities of water have to be pumped against low heads, mixed-flow volute (MFV) pumps are used because it is possible to get higher efficiencies than with radial flow pumps.

Mixed flow impeller – medium head – medium flow

Liquid enters the impeller axially and is discharged both axially and radially. In this case the head developed is the result of a combination of the centrifugal force and the lift produced by the vanes on the liquid.

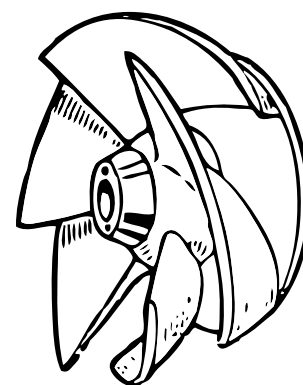

Turbine pumps

Turbine pumps are mixed-flow and axial flow pumps which direct water to the discharge outlet with diffusion vanes. Turbine pumps are most often used for pumping from bores. Because the bore hole diameter limits the impeller size, the pressure which can be developed at a given speed is also limited. High pressures are achieved by adding extra impellers, called stages, to the pump. These are called multi-stage pumps.

Axial flow impeller – low head – high flow

Liquid enters and leaves the impeller in an axial direction. In this case the head developed is entirely due to the lift produced on the liquid by the vanes.

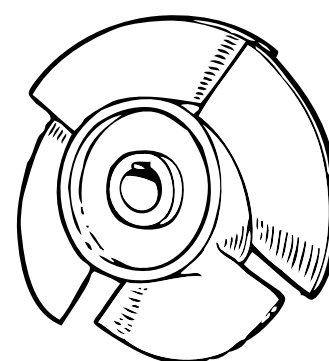

Variable speed pumping

The popularity of variable speed pumping appears to be growing, largely in response to increasing attention on energy costs. Variable speed pumping is achieved when the speed of a pump is adjusted by a variable speed drive (VSD). Whilst these may be both mechanical and electrical in nature, the most popular type is the electrical variable frequency drive (VFD).

Selection of a variable speed pumping unit may be most appropriate where a pumping system requires capacity to provide for a variation in flow or pressure. For example, where the area of centre pivot irrigation changes due to intermittent end gun operation, or where multiple centre pivots are supplied by a shared mainline. In

the past, such situations may have been addressed by selecting a pump capable of meeting the greatest output demand and the use of bypass lines or throttling valves. However this often results in a duty point which consumes unnecessary power.

The selection process for variable speed pumping units is very important, especially as these systems can require additional capital cost. A variable speed pump is not the solution for every situation, and this may be particularly the case where static head is a large component of total head. This is because such systems can have a fairly flat system curve (see below for more information on pump curves) and therefore pump efficiency can reduce quite quickly for only small changes in pump speed.

Furthermore, multi-stage pumping systems, consisting of a combination of constant and variable speed pumps, might provide a more flexible or cost effective solution than a single variable speed pump with the same maximum capacity. An appropriate analysis of pump performance should be undertaken before investment and the use of independent advisors may be beneficial to compare the widest range of possible solutions.

More information on variable speed pumping can be found in resources such as:

[Variable Speed Pumping - A guide to successful applications](#)

[Variable Speed Driven Pumps - Best Practice Guide](#)

Pump duty

The term 'pump duty' defines the operating conditions of a pump doing a certain job. Pump duty has two components:

- the **flow rate**, and
- the **head or pressure**

Flow rate

The flow rate is the quantity of water your pump is required to deliver over a specific period of time. It is commonly expressed as **litres per second (L/s)**.

A designed irrigation system should have the flow rate or range of flow rates specified. It is good practice to check your flow rate regularly to determine if your system is still operating as it should. Changes to the flow rate in your irrigation system may be due to wear in the pump, blocked or worn sprinkler components, corrosion in pipes and valves, and changed number or size of outlets.

Accurate measurement of your flow rate is essential. Refer to WATERpak Chapter 1.7 for further information on metering.

Some other flow rate terms:

kilolitres per hour (kL/hr) or 1,000 litres per hour

megalitres per hour (ML/hr) or 1,000,000 litres per hour

megalitres per day (ML/d) and

cumecs (m³/second) (1 m³ = 1,000 litres)

Note that some overseas manufacturers use gallons per minute (gpm) - this can be common for centre pivot and lateral move systems. **Be Careful!** Imperial (UK) Gallons and United States Gallons are different!

1 Imperial gallon = 4.55 litres

1 US gallon = 3.79 litres

Head

Head is the term given to the pressure that a needs to be supplied for a specific pumping task. It is often expressed in metres, meaning the pressure at the bottom of an equivalent vertical column of water at sea level.

1m Head – 10kPa – 1.45 psi

1psi – 6.89kPa – 0.69m Head

It is better termed **Total Head (H or TH)** because it is made up of four components added together:

- Static Head (SH)**
- Friction Head (FH)**
- Pressure Head (PH)**
- Velocity Head (vh)**

Static Head (SH)

The difference in height between the water level and the outlet is called the static head.

This can be broken into two components:

- Suction Head or Lift (SuH)
 - vertical height difference between the water level and centre line of the pump
- Delivery Head or Lift (DH)
 - vertical height difference between the centre line of the pump and the water outlet

Friction Head (FH)

Some loss of head occurs in all pipes and fittings in the system due to friction. The amount lost increases with higher flow rates, smaller pipes, pipe length and rougher materials. Smaller pipes may cost less to purchase but they create additional head through increased friction.

For instance:

- Distributing 400 L/s (35 ML/d) through a 450 mm concrete pipe will result in a friction head loss of 1.1 metres in every 100 metres of pipe length. The same flow through a larger 600 mm pipe results in only 0.25 metres of head in every 100 m of pipe.
- 675 mm concrete pipe carrying 78 ML per day and lifted 3 m has water velocity around 2.5 m/s. The friction losses from the suction pipe entry and the discharge pipe outlet become significant, perhaps as much as 40% of the Total Head.
- 200 mm (8 inch) PVC pipe carrying 35 L/s will result in a friction head loss of 0.42 m (4.2 kPa) in every 100 metres of pipe length, whereas a larger size 225 mm (9 inch) pipe will only lose 0.25 m (2.5 kPa) of head in the same length of pipe.

Pressure Head (PH)

Pressure Head is the pressure required to make an emitter (eg. sprinkler, dripper, etc.) work. It is also known as the operating pressure.

The pressure at or near an outlet is measured by a pressure gauge which should read in kPa. To convert this to metres of head, divide by 10. For instance 300 kPa = 30 m head.

Note: Pressure gauges should be checked to ensure they are reading accurately. Pressure gauges become inaccurate after a few years, or, if attached to a pump, maybe only after a few months.

Velocity head (vh)

This is the kinetic energy, or energy due to motion, in the water at any point.

Generally the numeric value of velocity head in a pipeline is quite small compared to Total Head and often disregarded. For example, water flow velocities in pipes up to 3 m/sec give velocity head values of less than 0.5 metres or 5 kPa which maybe only 1–2% of a pressurised system.

When large volumes of water are pumped against a low head (eg. storm water harvesting), Velocity Head in the pipeline may be a significant amount of the Total Head. This results from having no Pressure Head (because the discharge is an unrestricted pipe) and the high kinetic energy of a very large volume of water moving at high speed.

For example, water pumped at 78 ML per day through a 675 mm concrete pipe and lifted 3 m has water moving at around 2.5 m/s. The Velocity Head is 0.32 metres. This is around 11% of the Total Head. The design should evaluate the costs of larger pipe sizes vs operating savings from lower friction and velocity head.

When water leaves a pipeline, say through a sprinkler, Pressure Head is converted to Velocity Head which carries the water into the trajectory or pattern determined by the sprinkler design. This may be significant outside the pipeline but it does not impact on pump selection as Velocity Head was originally part of the nominated Pressure Head.

Figure 1.8.1. Components of Total Head

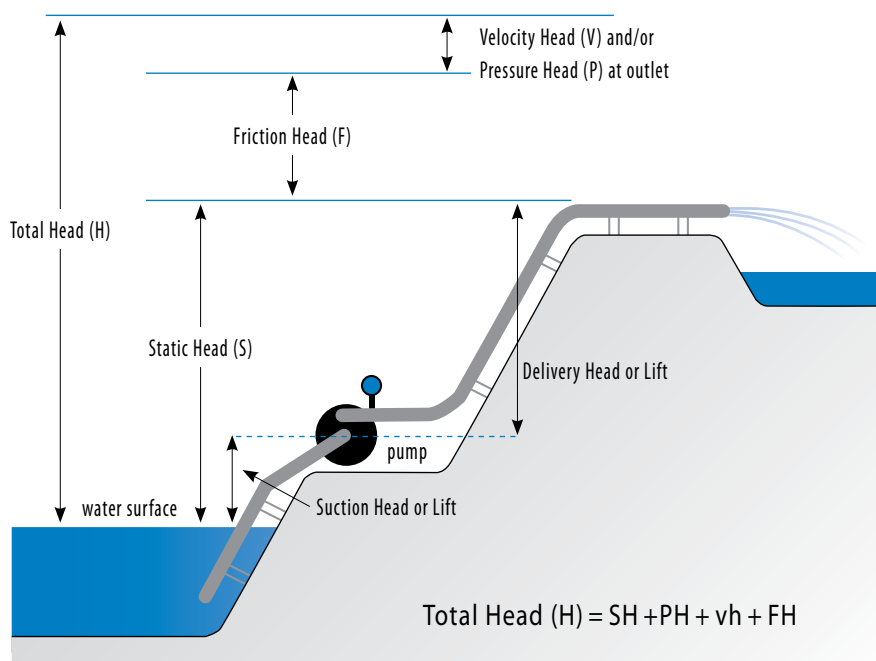

Example – Total Head

Calculating pumping head in metres

	Example – pressure	Example – surface
Static Head – Suction Lift (river to pump)	3.5 m	0 m (submersed inlet)
Static Head – Delivery Lift (pump to outlet)	5 m	3.0 m
Friction Head	8.5 m	0.1 m
Pressure at outlet in metres (100 kPa = 10 m)	$500 \text{ kPa} \div 10 = 50 \text{ m}$	nil
Velocity Head	0.5 m	0.4 m
Irrigator hose losses (if applicable)	$100 \text{ m} \times 76 \text{ mm poly} @ 8 \text{ L/s} = 12.5 \text{ m}$	n/a
Total Head	$3.5 + 5 + 8.5 + 50 + 0.5 + 12.5 = 80 \text{ m}$	$3.0 + 0.1 + 0.4 = 3.5 \text{ m}$

For pressurised systems, a simple way to find out the Total Head is by fitting a pressure gauge at or close to the outlet of the pump. The reading here is the combined Pressure Head, Friction Head and Static Head from the pump to the outlet. The Static Head from the pump to the water supply (the Suction or Static Lift) needs to be added to this to give Total Head.

At sea level, the pressure at the bottom of a pipe of water 10 metres high is about 100 kPa (14.5 psi).

Understanding pump curves

Pump manufacturers produce performance charts called pump (characteristic) curves. The main curves show the flow rate at various heads for certain impeller sizes or speeds. The curves for power required and pump efficiency are overlaid on the same axes for convenience. For computer selection of pumps, these curves are built into the computer software.

Flow v head curves

Figure 1.8.2 shows the curves for a particular pump at a set speed but with different impeller size options.

Figure 1.8.3 shows curves for the same pump with one particular impeller size at several different operating speeds.

Using either of these examples, the pump is capable of pumping at rates varying from about 2 L/s to about 10 L/s at a head varying from 15 metres to about 70 metres.

Larger pump examples are included later (Figures 1.8.7 & 1.8.8).

Figure 1.8.2. Pump curves for different impeller diameter at one speed.

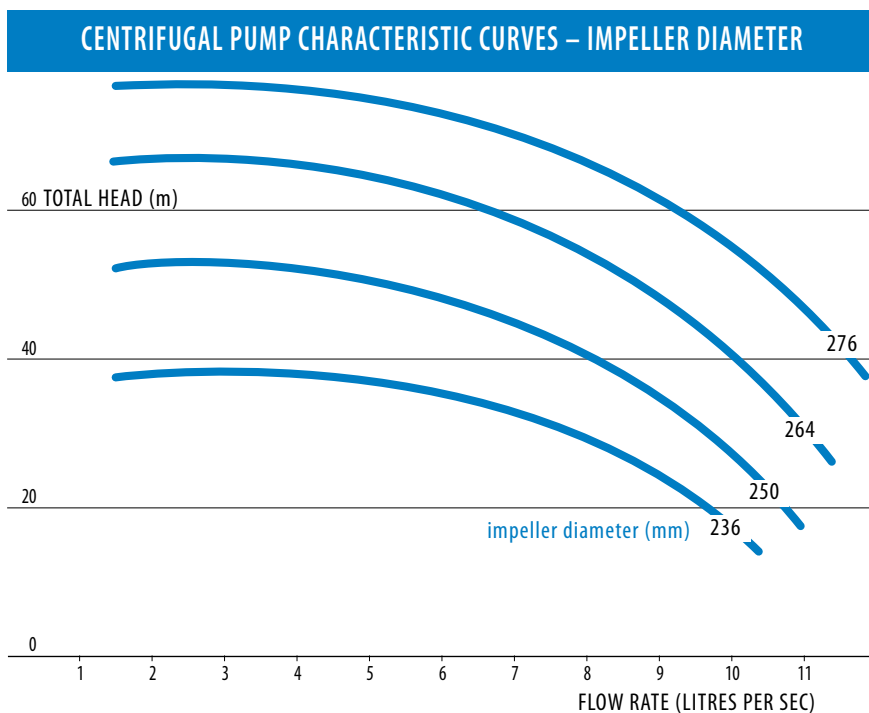
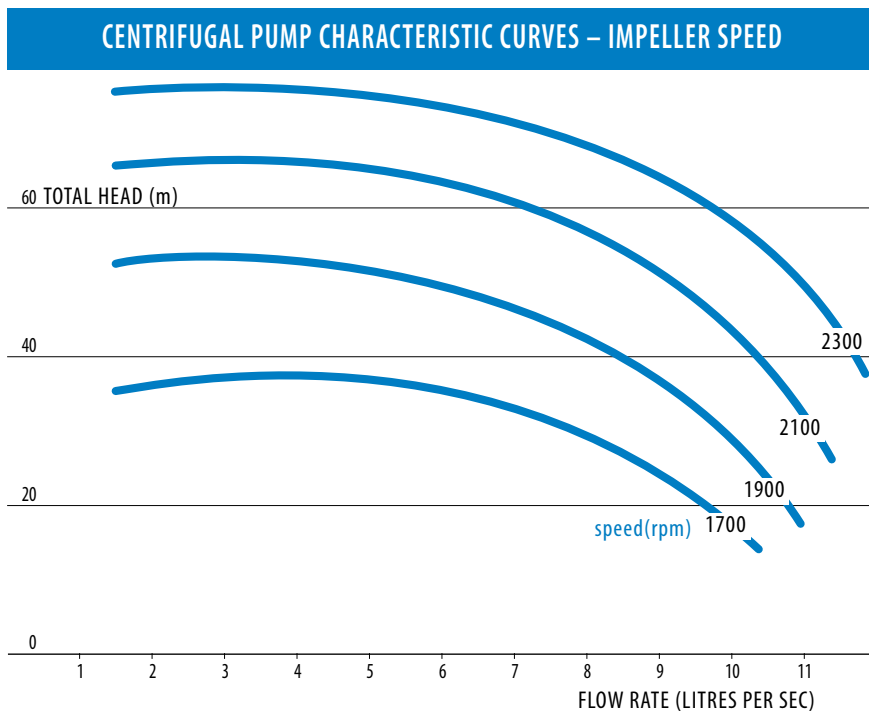

Figure 1.8.3. Pump curves for one impeller at different operating speeds.



Efficiency curves

The operating efficiency of the pump at each duty point is also marked on the pump curves. They are usually marked with percentages. They show how efficiently the input power (from the engine or motor) is transmitted into energy to pump the water at a particular duty point. This is the pumping efficiency. Like most mechanical devices, it is not possible to achieve 100% efficiency, primarily due to friction.

It is best to select and operate a pump near its peak efficiency. This results in more efficient use of electricity or diesel and thus reduced operating costs. Note that efficiency decreases if the flow rate is too high or too low and if the head is too high or too low.

Figure 1.8.4. Efficiency curves overlaid on Flow v Head curves

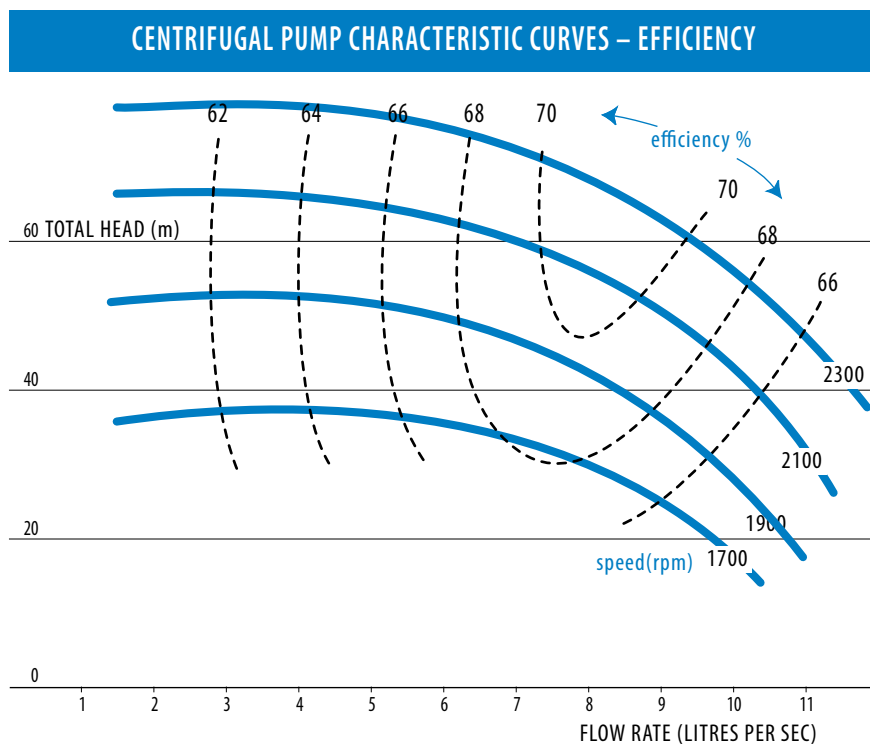

Power curves

The amount of power required to drive the pump (at the pump shaft) is also shown across the other curves (Figures 1.8.5 & 1.8.6) or separately (as in Figure 1.8.8). The power curve is usually marked in kW (kilowatts). You can work out the power at any point by estimating the figure from the closest power curve.

NB. This is the NET power required. Typically the prime mover needs to be 20% more for an electric motor, and 40% more for an internal combustion engine.

Figure 1.8.5. Power curves overlaid on Flow v Head curve

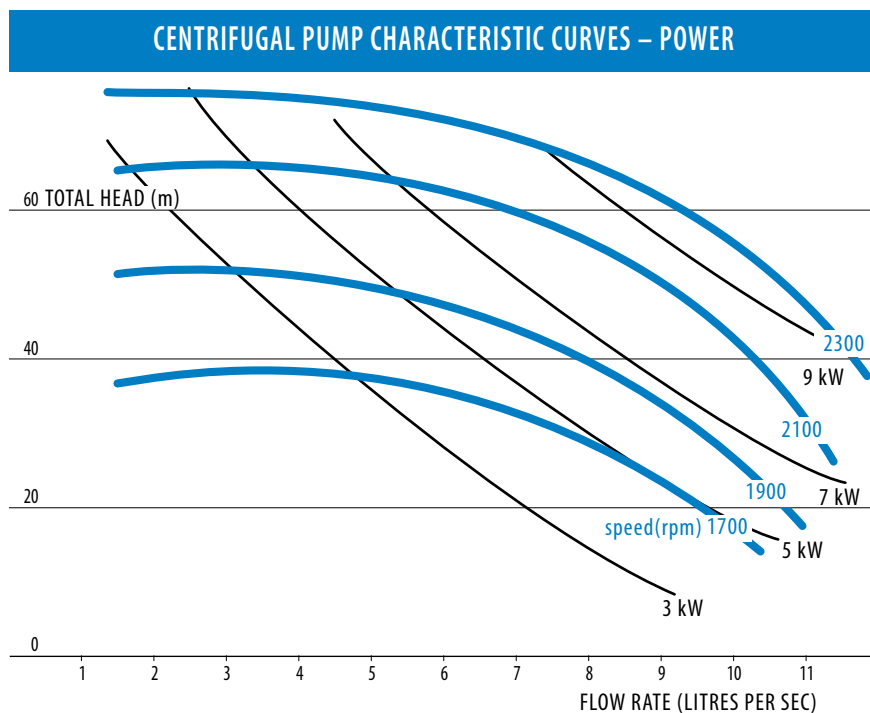

NPSHR

Pump curves supplied by manufacturers often show a separate curve that gives the “Net Positive Suction Head Required” (NPSHR). An example is in Figure 1.8.6. This is the ability of the pump to suck water from the supply source (eg. creek) without causing cavitation of the pump. (Some manufacturers, eg. Macquarrie, use the term H_s for NPSHR.)

Turbine pumps are usually fully submerged, including the pump inlet. This means there is no suction lift. Care needs to be taken that the inlet is submerged according to the supplier’s specifications to avoid vortexing and sucking air.

NPSH is discussed in more detail in the pump selection section.

Figure 1.8.6. Complete centrifugal pump curve

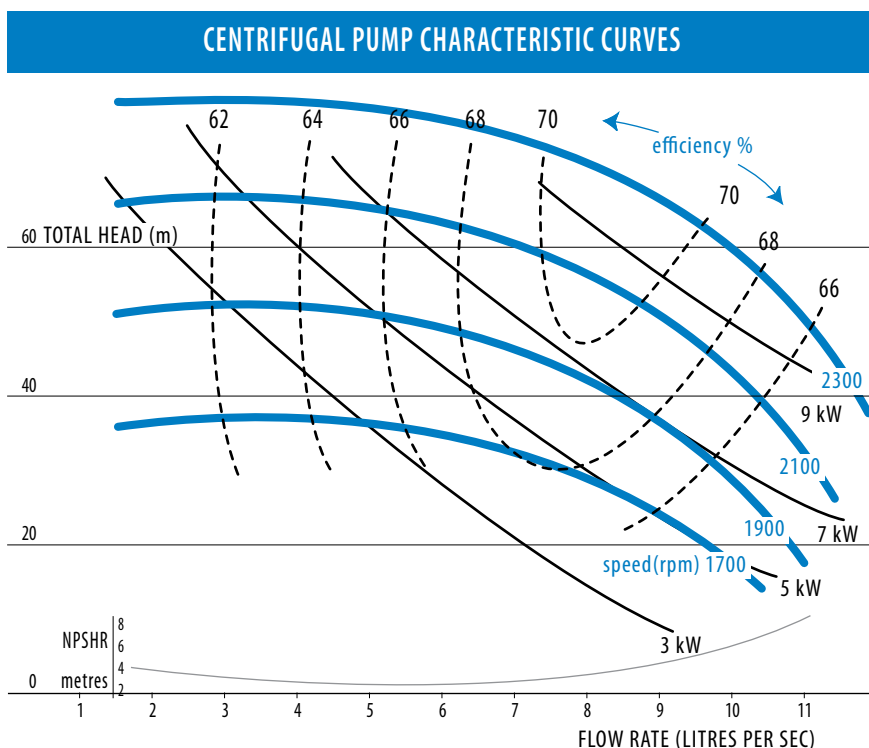

Figure 1.8.7. Example of curves for a mixed flow pump

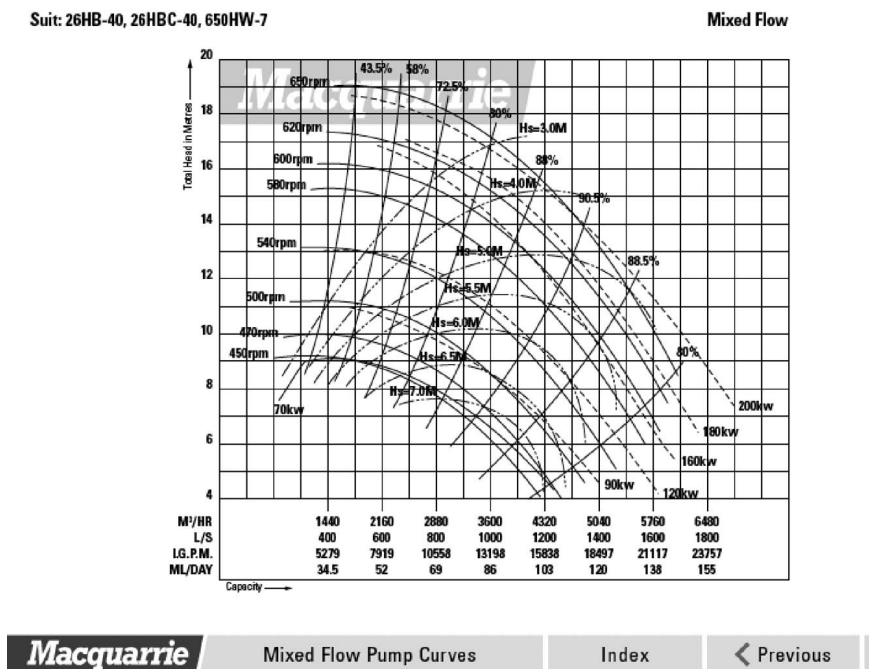

Figure 1.8.8. Example curves for a radial flow pump.

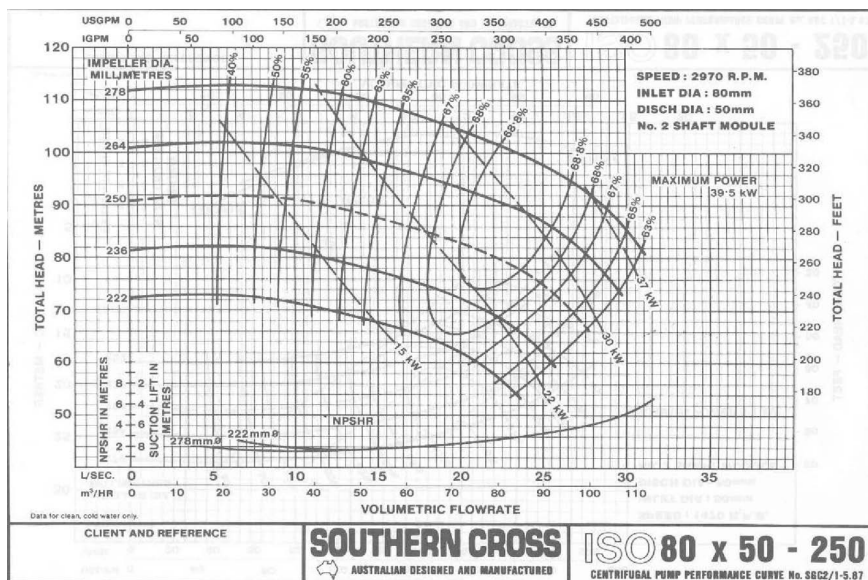
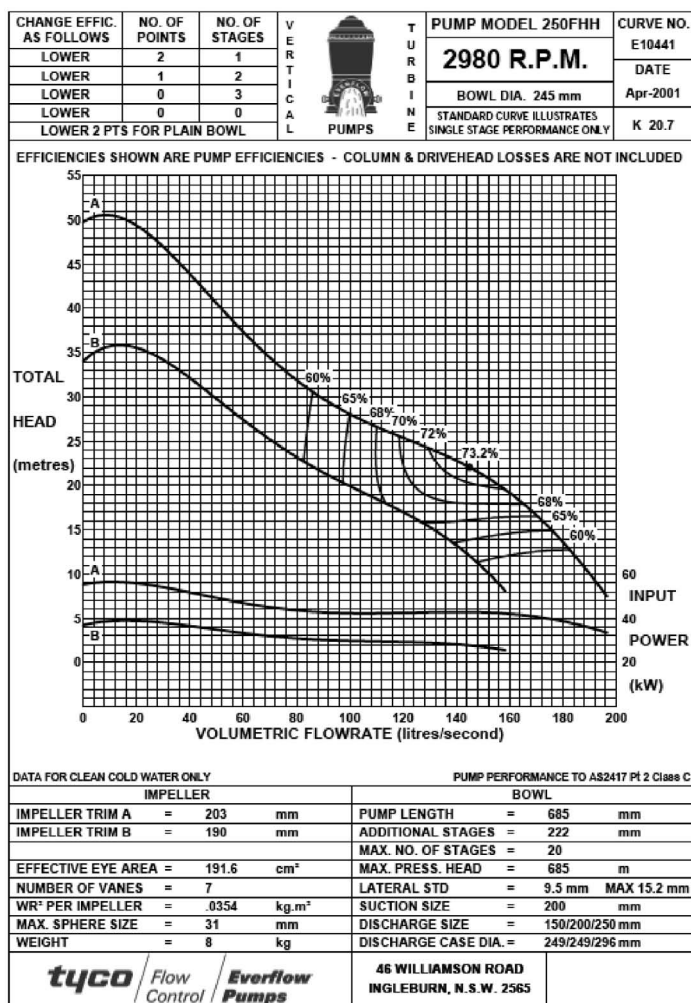

Chart 1.8.9. Example of curves for a turbine pump.



Pump efficiency and power requirements

For most irrigators, energy costs and energy efficiency are of major concern due to recent increases in energy costs and uncertainty regarding likely future increases. Pumping constitutes a major component of the total energy costs for most irrigation enterprises; for example the National Centre for Engineering in Agriculture found irrigation was typically between 40% and 60% of the total energy costs on irrigated cotton farms ([NCEA - Energy in Cotton](#)). Therefore improvements in pump efficiency can contribute to significant reductions in production costs.

From the pump charts, the theoretical pump efficiency can be determined. This section outlines how to calculate the **actual** pump efficiency. This value may be lower because:

- the wrong pump was chosen for the job
- the pump is worn and needs repair
- it is performing a duty different to the original design

If a pump is not working to maximum efficiency it will cost more than it should to operate. The pump duty and the energy being consumed should be shown on design plans, with this you can benchmark your pump's operating costs and efficiency over time. This indicates if it is still operating satisfactorily.

Pump efficiency of 70 to 85% should be achievable in most circumstances. An acceptable minimum is 65%.

Determining pump efficiency and operating costs

To find out if your pump is performing appropriately, a three step process is needed:

1. determine the theoretical efficiency and power requirement
2. determine the actual efficiency and power requirement, and
3. compare the difference.

Calculation of Pump Power requirement is achieved using the following equation:

$$P = Q \times H \div Pe$$

Where: P = Power (kW), Q = Flow Rate (L/s),
H = Head (m) and Pe = Pump Efficiency (%)

or

$$P = (Q \times H) \div (Pe \times 100)$$

Where: P = Power (kW), Q = Flow Rate (L/s),
H = Head (m) and Pe = Pump Efficiency (decimal)

Step 1 – Determining theoretical pump efficiency and power requirement:

The theoretical pump efficiency and power requirement can be read directly from the pump chart. Alternatively, it can be calculated as follows:

- Flow rate (Q)
= 93 ML/d (1076 L/s)
- Total head (H)
= 7 m
- Efficiency from the pump curve (Pe)
For pump '26HBC-40' (Chart 1.8.6)
= 89% (or 0.89)
- Theoretical Power required at the pump for this 'duty' and efficiency.
= $Q \times H \div Pe = 1076 \times 7 \div 89 = 85 \text{ kW}$

Step 2 – Determining actual pump efficiency and power requirement

To determine what is actually happening to an installed pump, we need to take some initial measurements. The power equation above contains 4 parts:

- **Flow rate** – we can measure this
- **Head** – we can measure this
- **Power** – we can determine this by measuring energy (electricity or fuel) usage
- **Pump Efficiency** – this is what we need to calculate

By rearranging the power equation above:

$$Pe = Q \times H \div P$$

Measuring flow and head can be performed quite accurately. But measuring the energy used by the motor driving the pump includes inefficiencies in the motor and drivetrain as well as the pump. In order to calculate pump efficiency correctly, energy losses due to the motor, transmission, climatic conditions, etc. are accounted for through a process called **de-rating**. The tables on the following page provide the information needed to do this.



Table 1.8.1. Motor Efficiency (Me)
– electric motors

Power – Approx. motor efficiency
Below 5 kW – 82% (0.82)
5 to 15 kW – 85% (0.85)
15 to 50 kW – 88% (0.88)
50 to 100 kW – 90% (0.90)

Submersible motors lose about 4% more than air-cooled electric motors (eg. where **Me** is 88% for an air-cooled motor it would be 84% for a submersible). Voltage losses through long electrical cables may also be significant. This should be checked with an electrical engineer.

Table 1.8.2. Altitude losses (Dr)
– internal combustion engines

m above Sea level	100%, 1.00
200	99% (0.99)
400	98% (0.98)
600	97% (0.97)
800	96% (0.96)
1000	95% (0.95)

100% at sea level means no reduction of power due to altitude – this is 100% of the potential efficiency, not that the engine is 100% efficient.

The altitudes of some irrigation regions are:

Emerald Qld	189 m
Dalby Qld	344 m
Moree NSW	212 m
Gunnedah NSW	264 m
Dubbo NSW	260 m
Hillston NSW	122 m
Wagga Wagga NSW	147 m
Griffith NSW	134 m
Tatura Vic	114 m
Mudgee NSW	454 m

For example, a diesel engine located at Moree, NSW, will produce 99% of its stated power rating. This is expressed as a decimal, 0.99, for our calculations.

Table 1.8.3. Temperature losses – internal combustion engines (Dt)

Air Temperature °C	Naturally Aspirated Engine, % loss	Dt	Exhaust Gas Turbocharged Engine, % loss	Dt
20	0	0	0	0
25	1.8	0.982	2.8	0.972
30	3.6	0.964	5.6	0.944
35	5.6	0.944	8.0	0.92
40	7.2	0.928	10.8	0.892

For example, at 30oC a naturally aspirated engine will have a power loss of 3.6% ie. it produces only 96.4% of the power compared to 20oC. This means the temperature factor (Dt) is 0.964.

Turbocharged engines are typically already more efficient than naturally aspirated, so although the percentage loss due to air temperature is greater, the engine efficiency may still be higher.

Table 1.8.4. Transmission or Drive Losses (Df)

This table assumes the transmission is in good condition and set up properly ie. V-belts in good condition and tensioned, gear drive maintained, etc.

Transmission Type	Energy transmitted %	Df
V-belt drives	90	0.9
Gear drives	95	0.95
Direct drive	100	1.0

For example, a 100 kW motor connected by vee belts will only transfer 90 kW to the pump.



Standard speeds for electric motors are 1450 rpm and 2800 rpm. If the operating speed of the pump is the same as these, direct drive is usually employed. If it is different, a transmission will be needed to gear the speed up or down.

Step 2.1 – Determining energy usage – electric motors

It is important to understand the difference between energy and power. Power is the rate at which energy is used. When measuring electricity, power is usually specified in kilowatts (kW) and energy in kilowatt-hours (kWh).

$$\text{power (kW)} = \text{energy (kWh)} \div \text{time (h)}$$

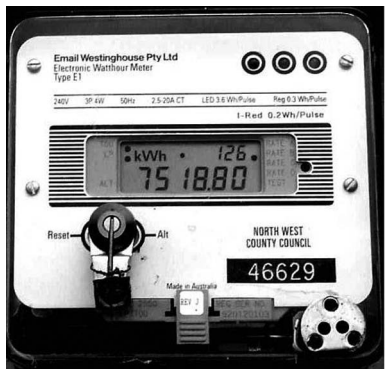
Table 1.8.5. Reading electricity meters

	Example
	First reading (R1)
	7517.29 kWh
	Second reading (R2)
	7518.80 kWh
	Multiplier (M)
	40
	For this example we will use a multiplier of 40 (often found only on the power bill)
	Difference between readings (C) (energy used during test time)
	$R2 - R1 = 7518.80 - 7517.29 = 1.51 \text{ kWh}$
	Total Energy Used (kWh) (E) (use the multiplier to obtain the actual energy use)
	$C \times M = 1.51 \times 40 = 60.4 \text{ kWh}$
	Time between readings in hours (T)
	30 minutes = 0.5 hours
	Power supplied (kW) (Ps) (this is the power supplied to the motor)
	$C \div T = 60.4 \div 0.5 = 120.8 \text{ kW}$

Power supply figures may also be used to indicate if the electric motor is correctly sized for the job – if the power supplied is about the same or greater than the rated kW for the motor, the motor is undersized and at risk of burning out.

Meters operate with different tariffs. Electronic types, such as the top picture, may have a separate register for each tariff, and each register is read separately from the one meter. For example, the off-peak tariff may be given register '203', and full tariff may be '126'.

Mechanical or disc meters, such as the lower picture, more commonly have one meter for each tariff.

There also may be one for each phase of a 3-phase power supply, in which case you should add the readings from each meter, provided you measure each meter at the same time and for the same length of time. If in doubt about how to read your meters, check with your electricity supplier.

Table 1.8.6. Calculate power supplied to pump.

	Example
Power supplied to motor (Ps), from above	120.8 kW
Electric motor efficiency (Me) Table 1	90% (0.9)
Drive factor (Df) Table 4	Gear drive = 0.95
Power supplied to pump (Pp), after derating	$P_s \times M_e \times D_f = 120.8 \times 0.9 \times 0.95 = 103 \text{ kW}$

Table 1.8.7. Calculating actual pump efficiency.

Actual pump efficiency (Pe) (using re-arranged power equation)	$Q \times H \div P = 1076 \times 7 \div 103 = 73\%$
Compare actual efficiency with theoretical efficiency	73% is less than the 89% on the pump curve, so improvements can be made!

Step 2.2 – Determining energy usage – Diesel Engines

A similar process can be done for pumps with diesel engines. Greater caution is needed, however, because there are more assumptions in this process.

The main assumption is that the diesel engine itself is running efficiently – if it is actually performing poorly, the results will indicate that the pump is running less efficiently than it really is. The measure of efficiency for internal combustion engines is called Specific Fuel Consumption. It is usually reported as litres of fuel used (L) divided by the energy (kWh) produced. It is difficult to measure so a reasonable estimate (at sea level at 25°C) for engines in good condition is about 0.25 L/kWh for most large diesel engines (over 70 kW) and 0.3 L/kWh for smaller engines.

The process requires some way of measuring diesel fuel consumption. The example below assumes the fuel tank is supplying only one engine and that it has a calibrated dip stick. The accuracy of the result will depend on how accurately the fuel consumption can be measured. (Calibrated dipsticks and flow meters can be obtained from retailers such as Australian Fuelling Systems & Equipment www.fuelequipment.com). (If using in-line fuel flow meters to obtain fuel consumption, ensure fuel return is taken into account.)

The Power equation is slightly modified to account for conversion of diesel fuel to energy:

$$P_e = (272 \times H \times \text{SFC}) \div (\text{L/ML} \times D_r \times D_f \times D_t)$$

Where:

272 – a conversion factor

SFC – Specific Fuel Consumption (as above) (L/kWh)

L/ML – Fuel use per ML of water pumped (L/ML)

H – Head

Dr, Df, Dt – De-rating factors.

Table 1.8.8 - Determining diesel fuel consumption

Fuel use	EXAMPLE
Start time (T1)	2.12 pm
First dipstick/meter reading (F1)	1800 L
Finish time (T2)	8.12 pm
Second dipstick/meter reading (F2)	1634 L
Fuel consumption (L/h)	EXAMPLE
$(F1 - F2) \div (T2 - T1)$	$(1800 - 1634) \div (8.12 - 2.12) = 27.7 \text{ L/h}$

Table 1.8.9. Calculating actual pump efficiency.

Specific Fuel Consumption (SFC)	0.25 L/kWh
Water flow rate (Q)	1076 L/sec = 3.875 ML/h
Fuel Use per ML Water Pumped = Fuel (L/h) ÷ Q (ML/h)	= 27.7 ÷ 3.875 = 7.15 L/ML
Pressure gauge or Delivery Head (DH)	7 m
Suction lift (SuH), assumed value	0 m
Total head (H), DH + SuH	7 m
Altitude derating (Dr), at 200m (Table 2)	0.99
Temperature derating (Dt), 30°C (Table 3)	0.964
Transmission (Df), gear drive (Table 4)	0.95
Conversion factor	272
Pump efficiency % (Pe) = (272 × H × SFC) ÷ (L/ML × Dr × Df × Dt)	= (272 × 7 × 0.25) ÷ (7.15 × 0.99 × 0.95 × 0.964) = 476 ÷ 6.482 = 73%
Compare actual efficiency with theoretical efficiency	73% is less than the 89% on the pump curve, so get pump checked further!

Because this efficiency figure is approximate, use it as a guide only. If it is much worse than the manufacturer's performance sheets indicate, have the pump checked by a pump specialist.

Is it worth taking action? – determine the cost/benefit

Determining if taking some action to improve your pump's performance is economically worthwhile involves some simple calculations.

The money lost by operating an inefficient pump can be substantial. The more water you pump when you use an inefficient pump the more money you lose.

Inefficient pumps may impact upon your enterprise in many ways, including:

- Increased fuel costs
- Production losses – reduced yield and/or quality
- Increased water use
- Environmental cost – greenhouse gas emissions in extra energy consumed

Calculating cost per megalitre pumped (electric):

Using the example data from the previous section:

First calculate the energy used per ML of water pumped. This can be calculated as follows:

Power supplied (kW) ÷ Flow Rate (L/s)
÷ 0.0036 (to convert L/s into ML/h)

Table 1.8.10. Calculating energy use per ML of water pumped (electric)

Power Supplied (Ps)	120.8 kW
Flow Rate (Q)	1076 L/s
Energy used per ML pumped (Z)	Ps ÷ Q ÷ 0.0036 = 120.8 ÷ 1076 ÷ 0.0036 = 31.2 kWh/ML

The above figure is useful for comparing your pumping performance regardless of energy costs.



The cost of pumping can now be calculated from your electricity tariff. If your electricity supplier has different tariffs for day, off-peak, weekends etc., base your calculation on the tariff most applicable to obtain a good estimate, or work out the cost for each tariff and time of operation to get an exact cost.

Table 1.8.11. Calculating the cost of pumping (electric)

Pumping cost per megalitre @ 15c per kWh $G = Z \times \$$	$G = 31.19 \times \$0.15$ $G = \$4.68 / \text{ML}$
Pumping cost per ML per metre head $= G \div H$	$= \$0.67 / \text{ML} / \text{m head}$

Calculating cost per megalitre pumped (diesel):

Using the diesel example from the previous section.

Table 1.8.12. Calculating the cost of pumping (diesel)

Cost of diesel per litre on-farm	$\$ 1.10 / \text{L}$
Pumping cost per ML (G), $\text{L}/\text{ML} \times \text{cost}$	$= 7.15 \times 1.10 = \$7.87 / \text{ML}$
Pumping cost per ML, per metre head $= G \div H$	$= 7.87 \div 7$ $= \$1.13 / \text{ML} / \text{m head}$

Determining the cost/benefit of improving pump efficiency:

Using the diesel example from above; if your pump is 73% efficient and your pumping cost is \$7.87/ML, how much would be saved by improving the efficiency to the original design efficiency of 89%?

Saving per ML

$$= \$7.87 - (\$7.87 \times 73 \div 89)$$

$$= \$7.87 - \$6.46$$

$$= \$1.41$$

For a season where 1200 ML are pumped, the total cost saving would be:

$$\$1.41 \times 200 = \$1692.00$$

If the cost of replacing the pump is \$9,500 and the impeller \$1,800, the cost of replacement is recovered in less than 6 seasons and repair in a little over 1 season.

Notice that a **reduced pump efficiency** of 16% (89% down to 73%) **increases** the cost of pumping by 22% (from \$6.46 to \$7.87 per ML).

Additionally, production losses from poor operation of a pressure irrigation system are likely to far exceed these pump operation losses, so serious consideration would be given to replacing the impeller earlier.

Pump selection using performance curves

Do not make your choice of a pump simply on cost. The pump on sale at the local supplier or the second-hand one for sale next door is unlikely to meet the demands of your system and crop.

1. Select the duty point

To select a pump, the duty point must first be known. The pump must be matched to the requirements of the irrigation system, not vice-versa. For a new irrigation system, the flow rate (Q) and total head (H) should be readily obtained from the irrigation design. For an existing system, measure them using the methods described earlier.

The duty point will be the intersection of the flow rate and the total head. Once the duty point is known, locate it on the H-Q curve for a pump. If you cannot locate the duty point on a particular curve, then that pump will not suit your task. For example, for a centre pivot with a duty point of 120 litres per second and pump pressure gauge reading or Total Head of 250 kPa (25 metres):

Note the impeller size and speed – for

Figure 1.8.9. Select the duty Point

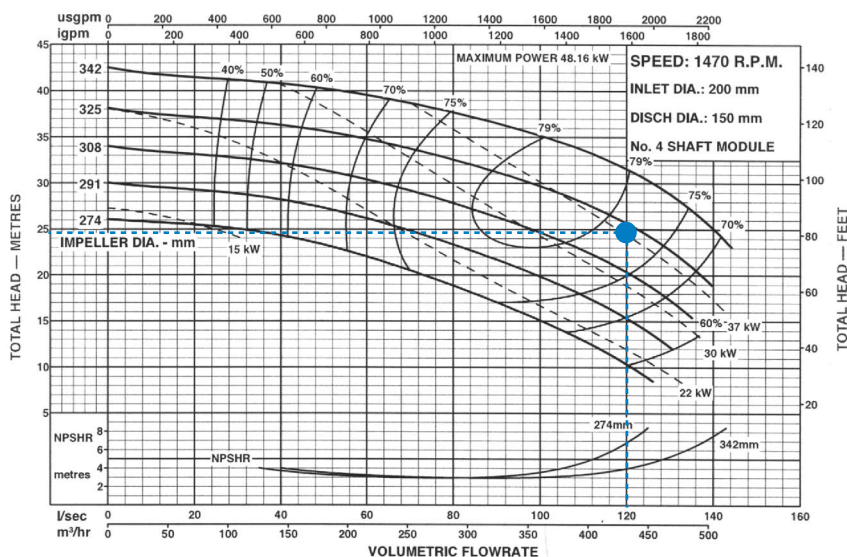

this example the size is 325 mm and the speed is 1470 rpm.

2. Check the pump efficiency

When the duty point is located on the H-Q curve, find the corresponding efficiency on the efficiency curve. The aim is to have the efficiency as high as possible. If it is below 65%, try another pump/curve. For most irrigation systems, you will find a number of pumps over 65% – select the highest efficiency unit that has a competitive price. In the example below, the efficiency is 78%.

3. Check the suction lift efficiency

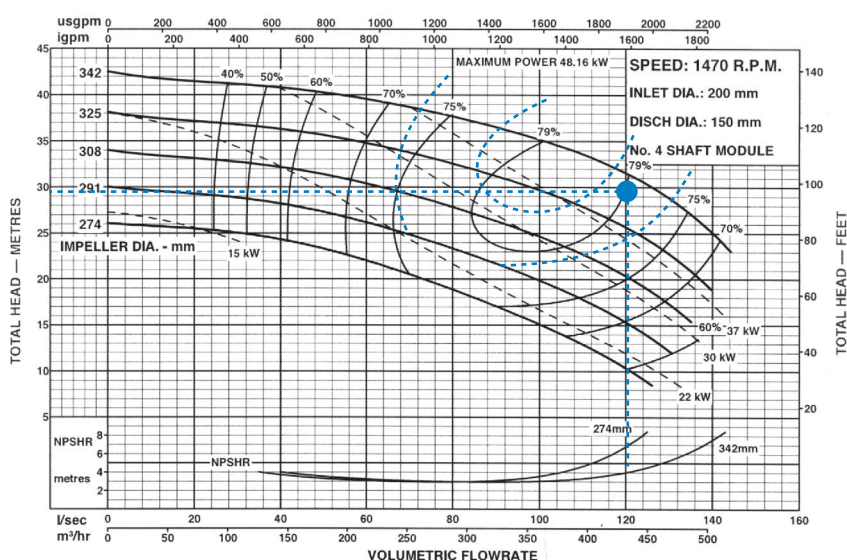

Required. The theoretical maximum vertical height any pump can lift water is about 10 metres at sea level, less than 10m at higher altitudes. The NPSHR is the amount of this 10 metres used by the pump just getting the water into it. If the suction lift or height is more than what is left, the pump will cavitate or simply not pump water.

Suction lift is the vertical distance between the water level and centre of the pump. It can be measured directly or read from the irrigation

design plan. The suction lift often varies with river height, storage level, bore depth, etc. so the greatest likely figure should be used for pump selection.

Read the NPSHR from the curve, subtract it and the Friction Head of your suction pipe from the average atmospheric pressure (10 m at sea level), and check that it is less than your suction lift. If not, try another curve. Pressure variation due to altitude is indicated in the table.

Altitude (m)	Atmospheric pressure (m)
Sea level	10
500	9.5
1,000	9
5,486	5

What is Net Positive Suction Head (NPSH)?

Net Positive Suction Head (NPSH) is the head that causes water to flow into the pump. The water is pushed by the atmosphere into the pump because there is negative pressure, or suction, at the eye of the impeller.

Net Positive Suction Head Required (NPSHR) is a function of pump design and varies between make of pump, type of pump, speed and capacity. This value is usually found on the pump performance curves.

Net Positive Suction Head Available (NPSHA) is the available head at the suction flange of the pump and is a function of the suction pipe system. NPSHA must be greater than the NPSHR. A conservative minimum is 1 metre.

Max Suction Lift

= Atmospheric pressure – NPSHR – suction pipe friction
 = 10 – NPSHR – suction pipe friction

For the example below, the NPSHR for a 325 mm impeller is 5 m.

Max Suction Lift

= 10 – NPSHR – suction pipe friction
 = 10 – 5m – 1m (est) = 4m

Figure 1.8.11. Check the suction lift

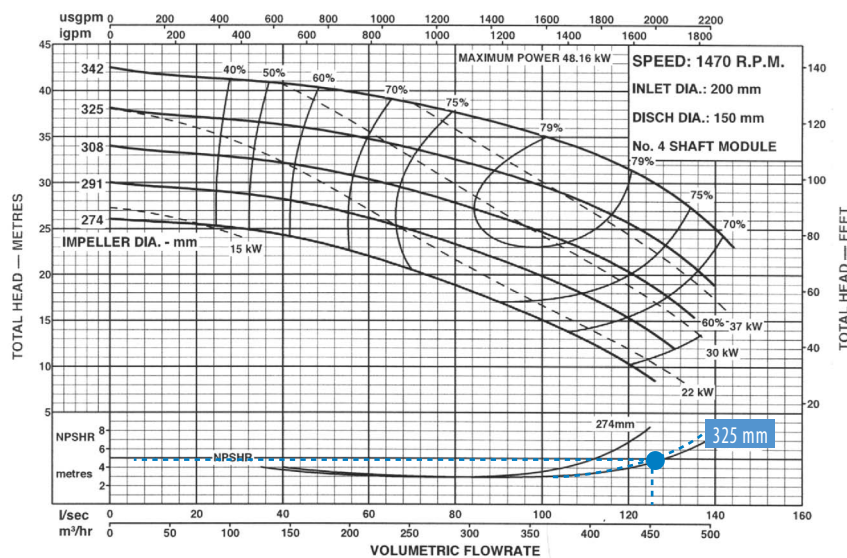
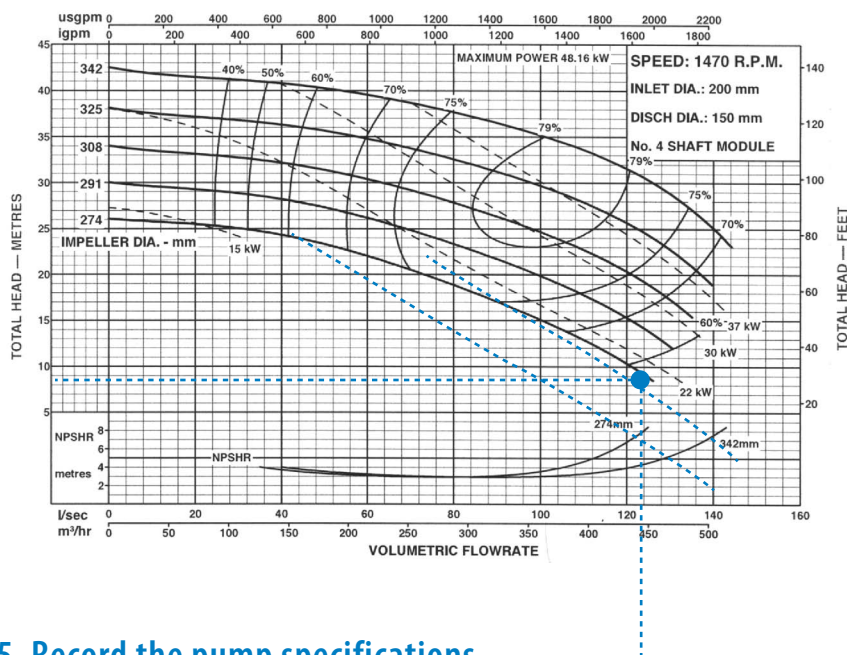

Figure 1.8.12. Determine the pump power required



5. Record the pump specifications

Having found a suitable pump, write down all the specifications. There are many pumps from many manufacturers available, often appearing very similar, so every important piece of information should be recorded to ensure you get the pump you've selected.

Table 1.8.13. Pump specifications

	Pump Choice 1	Pump Choice 2	Pump Choice 3
Discharge Q (L/s)	120 L/s		
Total Head H (m)	25 m		
Pump Brand	Pumpit		
Pump Model	Whoosher		
Impeller Size (mm)	325 mm		
Impeller type	Fully enclosed		
Pump Speed (rpm)	1470 rpm		
Efficiency Pe (%)	78% (0.78)		
Nett Power required (kW)	38 kW		
NPSHR (m)	5 m		
Inlet size (mm)	200 mm		
Outlet size (mm)	150 mm		
Transmission	Direct drive – electric v-belt – diesel		

6. Determine the drive unit size

Double check the power required at the pump by calculation:

$$\text{Power (kW)} = Q \text{ (L/s)} \times H \text{ (m)} \div Pe \div 100$$



For our example:

$$\text{Power} = 120 \text{ L/s} \times 25 \text{ m} \div 0.78 \div 100$$

$$= 3000 \div 0.78 \div 100 = 38.5 \text{ kW}$$

It is advisable to choose a motor or engine that provides for additional power in reserve. This means the power unit will not be struggling to do its task, and as it ages it will still perform satisfactorily. As a guide, for electric motors add 10% to the calculated figure, and 30% for internal combustion engines:

Size of electric motor to purchase = Pump power + derating factors + 10%

Size of diesel engine to purchase = Pump power + derating factors + 30%

Table 1.8.14. Derating – electric

Motor efficiency M_e (as a decimal)	0.88
Submersible?	No
D_f (as a decimal)	1.0
Electric motor power required (kW)	$= \text{kW} \div M_e \div D_f (+ 10\% \text{ reserve})$ $= 38.5 \div 0.88 \div 1.0 (+ 10\%)$ $= 43.8 \text{ kW} (+ 4.4 \text{ kW}) = 48.2 \text{ kW}$ 55 kW is the nearest stock electric motor

Table 1.8.15. Derating – diesel

Altitude (m) D_r	200 m – 0.99
Turbo?	Yes
Air temperature ($^{\circ}\text{C}$) D_t	40 $^{\circ}\text{C}$ – 0.892
D_f (as a decimal)	0.9
Diesel engine power required (kW)	$= \text{kW} \div D_r \div D_f \div D_t (+ 30\% \text{ reserve})$ $= 38.5 \div 0.99 \div 0.9 \div 0.892 (+ 30\%)$ $= 48.4 \text{ kW} (+ 14.5 \text{ kW}) = 63 \text{ kW}$

Pump maintenance

All pumps and their power sources need to be correctly maintained for efficient operation. Any change can have a major effect on operating efficiency. A check of your pump and fittings should be carried out before each irrigation season.

Table 1.8.16. Installation and maintenance checklist

Things to do:	Things not to do:
<ul style="list-style-type: none"> • site the pump as close as practical to the water • make sure suction and delivery pipes do not strain the pump casing • check that all pipe connections are tight and suction lines are airtight • use a strainer recommended by the pump manufacturer • anchor the pump securely so that it doesn't move during operation • work the pump within its limits • provide ventilation for the motor or engine • keep pump and motor connection aligned • make sure pump is primed before starting • keep the strainer clean • service the pump regularly 	<ul style="list-style-type: none"> • do not operate pump without water • do not operate pump for long if discharge valve is closed • do not operate pump if strainer is blocked • do not operate pump if it is vibrating excessively • do not install suction pipes so that air can build up in them.

Managing water in plant nurseries by C. Rolfe, W. Yiasoumi, E. Keskula, NSW Agriculture 2000, p.196

Suction

A major cause of poor pump performance is problems in the suction line. Things to look for on the suction side of the pump are:

- *Suction lift too high*
About 4.5 metres from the water level to the pump is generally the maximum recommended lift. This will vary with the pump and its duty and should be checked with your local pump distributor. Excessive lift causes cavitation and perhaps damage to the pump. If the pump is cavitating it usually sounds like it is pumping gravel.
- *Air pockets*
Incorrect installation of suction pipes and fittings may cause pockets of trapped air. These reduce the effective internal diameter of the pipe or fitting and create additional friction loss.
- *Air leaks at joints*
Air entering through joints or through the footvalve causes a severe drop in pump performance and causes damage to the pump itself. Check all joints for leaks and if necessary replace any worn flange gaskets.
- *Footvalve*
Ensure that the footvalve is sufficiently submerged below water level to prevent a vortex of air being drawn into the suction. A minimum depth of about 0.5 metres is desirable. Ensure the footvalve is not blocked with sand, weed, algae, or other foreign matter.



Figure 1.8.13. Pump suction line setup.

Suction lines that are not set up correctly are a source of inefficient pump performance.

Here are some common examples:

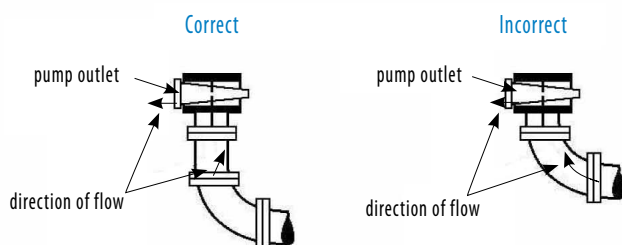
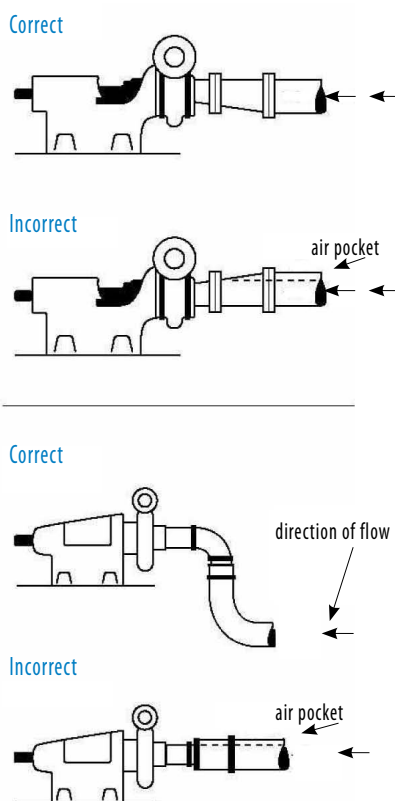
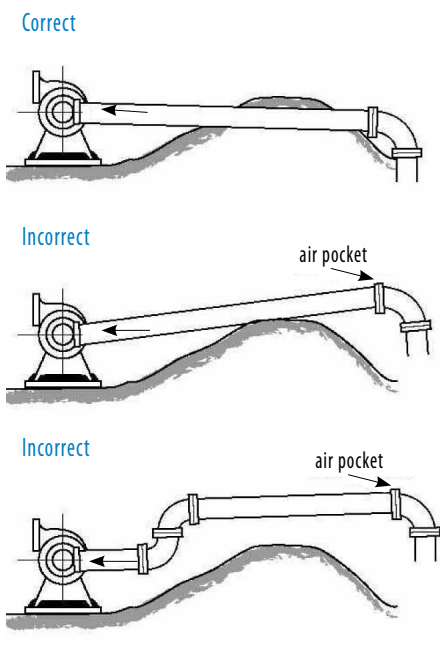

- **Packing Glands**
The packing gland material should be replaced periodically and the gland follower should not be too tight. A steady drip from the gland is normal and is an indication of correct adjustment. If the pump at the packing gland is running hot it indicates the gland follower is too tight and should be loosened to allow more water leakage.
- **Mechanical Seals**
If the pump has a mechanical seal, as opposed to a packing gland, then leakage indicates the mechanical seal to be worn and in need of replacement.
- **Impeller**
The impeller should be inspected for general wear of the vanes and the face. The clearance between the impeller wear ring and suction eye ring should be measured accurately. Generally this clearance should be in the range of 0.13 to 0.25 mm. This should be confirmed with the pump manufacturer. A clearance outside the pump manufacturer's range indicates new wear rings or a new impeller are needed.
- **Pump Shaft**
This should be checked for scoring and straightness. Shaft straightness can be checked by using a dial indicator on the impeller end of the shaft while the shaft is supported on the bearing housing. The total run-out should not exceed 0.05 mm.

Pump

Main check points on the pump are:

- **Bearings**
A screwdriver (preferably one with metal through the handle) held against the pump near the bearings and also held against the ear will help check for bearing wear. A smooth hum will indicate the bearings are sound. A grinding noise, rattle or bumping noise indicates bearings are worn. Bearings should be lubricated to manufacturer's recommendations. Hot bearings can be an indication of too much grease. If the bearings are oil lubricated the oil should be changed annually or every 1000 running hours, whichever comes first.

- **The Pump Bowl**
The pump bowl, and also the impeller, should be cleared of any build-up of rust or corrosion. If there is wear or damage to the metal it can often be repaired by the use of a Water Resistant Epoxy such as Devcon®, Vepox cc 65® or Chesterton® Pump Repair Compound.
- **Seal & 'O' Ring**
The condition of the seal at the drive end of the shaft and the 'O' ring on the back cover should also be checked for wear and replaced if necessary.

Cavitation

Cavitation occurs when a pump has to get water from a height which exceeds its suction lift ability ie. the Net Positive Suction Head (NPSH) is not adequate. If cavitation is occurring during normal irrigation,

the suction lift is probably too high. Cavitation will damage your pump, decrease its performance and ultimately limit its life. A cavitating pump will usually vibrate and make a noise like gravel rattling in a drum.

Cavitation occurs because in the suction line the pressure on the water is reduced below atmospheric pressure. This causes the water to boil at ambient temperature and create tiny bubbles of vapour. When these bubbles reach an area of high pressure (at the face of the pump impeller) they collapse (implode). These implosions cause pitting and eventually holes in the impeller.

Cavitation is sometimes experienced when filling a pressure line at the start of an irrigation. Because the pressure takes a little while to reach operating level, the Total Head is temporarily low, and the flow rate is higher than the design duty. The higher flow increases the friction

head in the suction line and fittings. This causes a greater pressure drop in the suction line, which may result in cavitation. To overcome this, control the filling flow rate by closing the gate valve at the pump before starting up, and opening it slowly as the pipe fills.

Cavitation may also occur if the flow rate has increased, for example, through worn sprinkler nozzles, leaks, or extra sprinklers being added.

Common solutions for cavitation are to relocate the pump to a lower level or alter the pump duty, possibly by making a better pump selection or restoring the irrigation system to its original design. Seek the advice of an experienced designer.

Further Information

A range of pump factsheets can be found online, including:



NSW Department of Primary Industries:

[Selecting an Irrigation Pump](#)

[How much does it cost to pump?](#)

[Is your diesel pump costing you money?](#)

[How efficient is your pump?](#)



Growcom (horticulture):

[Pump Efficiency \(under the heading 'System Evaluation'\)](#)

